

**4 PRODUCT
TRACKED MOBILE
INCLINED SCREEN**



WORKS FOR YOU.

FINLAY 694+

Now with 'best in class' production levels, set up time and ease of operation, the **NEW** Finlay 694+ is the industry's leading tracked mobile inclined screen. A high capacity belt feed hopper is available with remote tipping grid or a single or double deck vibrating grid. The **NEW** triple deck screen configuration provides three full sized 20' x 5' (6.1m x 1.525m) screens. An innovative hydraulically controlled fourth conveyor allows simple adjustment with variable tilt and slew discharge for recirculation or stockpiling of finished material.

Oversize grade conveyor

- ▶ 800mm (32") Belt
- ▶ 4.7m (15' 6") discharge

Fines Conveyor

- ▶ 1200mm (48") Plain belt
- ▶ 5.2m (17' 1") discharge height

Screen Box

- ▶ 20' x 5' top deck (6.1m x 1.5m)
- ▶ 20' x 5' middle deck (6.1m x 1.5m)
- ▶ 20' x 5' bottom deck (6.1m x 1.5m)

Features:

- ▶ The **NEW** triple deck 20' x 5' (6.1m x 1.525m) screen box with full catwalk access is the largest and most accessible in it's class.
- ▶ A combination of quick wedge tensioning, convenient access holes, and hydraulic tensioning on the bottom deck ensure mesh set up and change out times are kept to an absolute minimum.
- ▶ Maximum utilisation of three 20' x 5' (6.1m x 1.525m) decks provide ultra-efficient screening capacities even at small aggregate sizes.
- ▶ The fourth (oversize plus) conveyor provides variable tilt and side slew capability to accurately discharge materials for recirculation to crushers or for stockpiling.

STANDARD FEATURES

Deutz water-cooled engine (100hp/75kw) c/w Pre-cleaner system (scavenger)

1200mm (48") wide variable speed belt feeder

4.25m (14') hopper - 8.0 m³ (10.5 yd³) capacity

Remote control hydraulic tipping reject grid c/w grouser bars
4.25m x 100mm spacing (14'-0" x 4")

6.1m x 1.52m (20' x 5') top, middle and bottom deck screenbox.

Top and middle deck Side Tensioned and Bottom Deck End Tensioned Mesh

Hydraulic tensioning (bottom deck screen mesh)

Quick wedge tensioning - top deck and middle deck

No mesh or speedharps included for any deck (but all mesh fitting parts included as standard)

Catwalk around screen c/w handrail, kick board and access ladder

1200mm (48") wide belt on main conveyor & 1200mm (48") wide fines belt

500mm (20") wide chevron belt on oversize plus product conveyor

800mm (32") wide chevron belt on oversize minus and middle grade side conveyors

Skirting on main conveyor & low level central greasing

Heavy duty undercarriage unit with 500mm wide tracks

Control operation of tracks via hand-held set with 5m connection lead with heavy duty square connector

Guards to M & Q specification

Emergency stops (4)



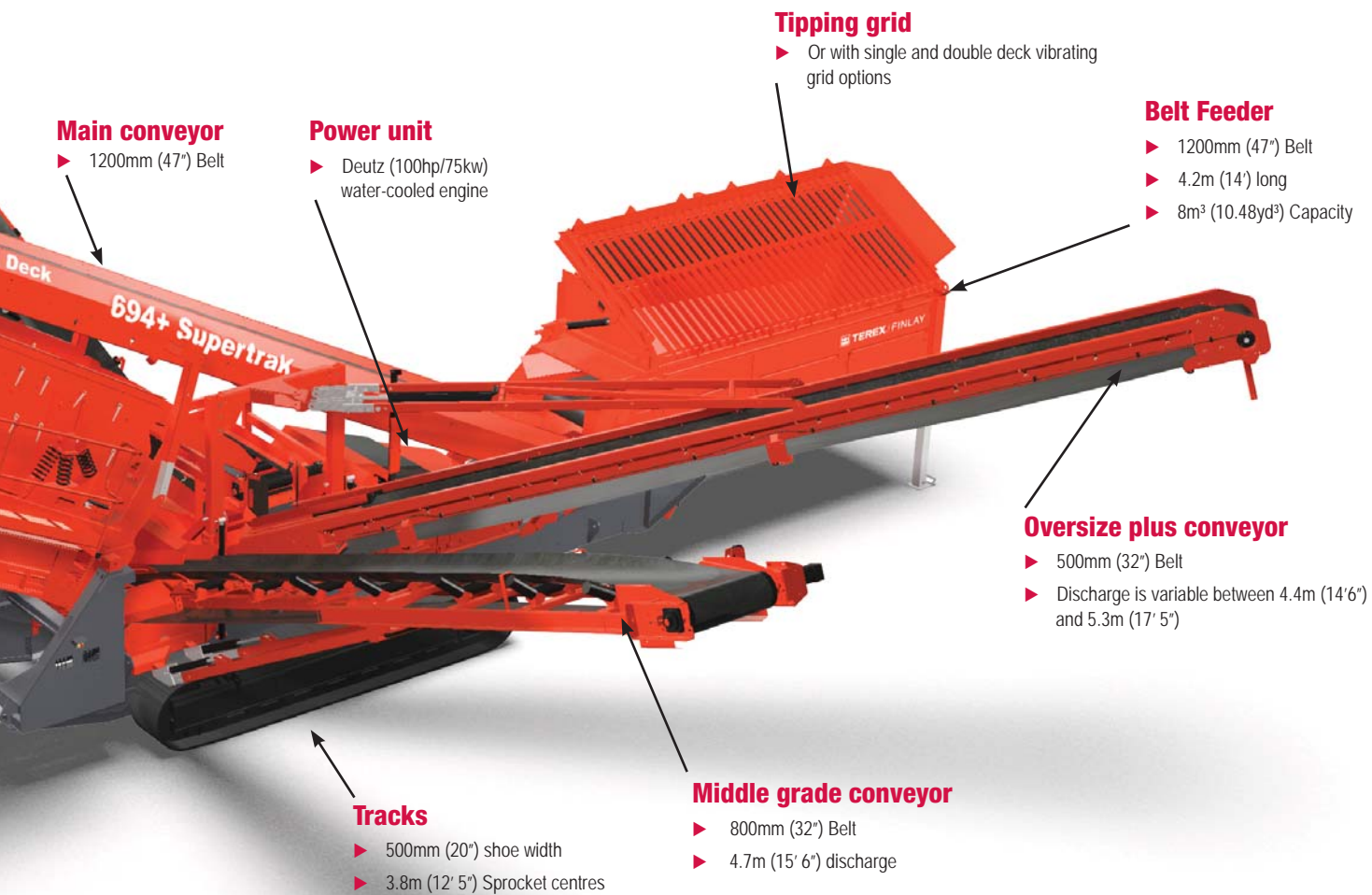

Transport Dimensions



Working Dimensions

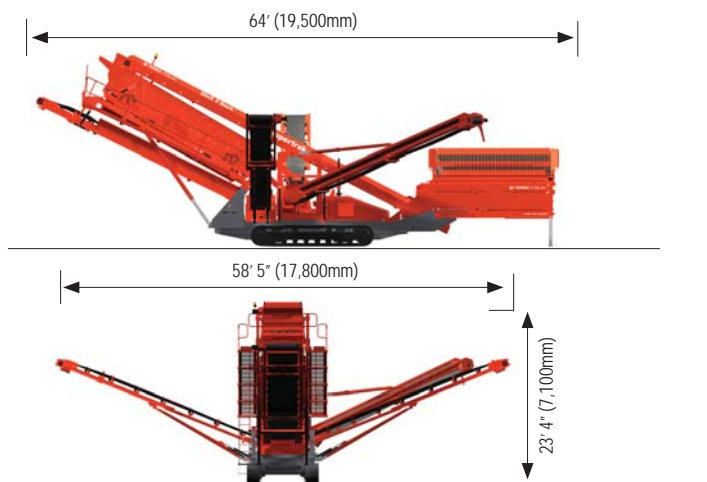

WORKS FOR YOU.

www.terexfinlay.com

Effective 08.02.10. Product specifications and prices are subject to change without notice or obligation. The photographs and/or drawings in this document are for illustrative purposes only. Refer to the appropriate Operator's Manual for instructions on the proper use of this equipment. Failure to follow the appropriate Operator's Manual when using our equipment or to otherwise act irresponsibly may result in serious injury or death. The only warranty applicable to our equipment is the standard written warranty applicable to the particular product and sale and Terex makes no other warranty, express or implied. Products and services listed may be trademarks, service marks or trade-names of Terex Corporation and/or its subsidiaries in the USA and other countries. All rights are reserved. Terex® is a registered trademark of Terex Corporation in the USA and many other countries. Copyright 2010 Terex Corporation.

Terex® Mobile Processing Equipment, Drumquin Road, Omagh, Co. Tyrone, N.Ireland. BT78 5PN
Tel: +44(0) 28 82 418 700 Fax: +44(0) 28 82 244 294



WORKS FOR YOU.