

# ECOHOOG®

## **EH-81 Airhog** Air Suction Separator

The Airhog EH-81 is a suction system designed for the removal of low value light weight fractions such as paper, plastics and foil from applications including compost, wood and other waste streams. The Airhog incorporates a frequency controlled heavy duty fan, air hose and extraction hood. The extraction hood is positioned over a moving waste stream (conveyor belt), the light weight material is blown through the extraction hood into a detachable sock or bin and the remaining higher density material continues to pass on the conveyor to the required resting place. The Airhog is a standalone unit designed with forklift lifting points and lifting eyes for craning to ensure ease of movement. The unit can be designed to fit any conveyance system.



### **KEY FEATURES**

- Removes unwanted contaminants improving quality downstream
- Reduces/Replaces manual sorting at lower costs
- Adjustable electronic fan speed controls
- Adjustable fittings suitable for various locations in the existing processing facility / setup
- Designed for movement via forklift
- High throughput
- Quick and easy setup

### **SUITABLE FOR**

- Compost
- Waste Wood
- Trommel Fines
- Glass Clean Up
- Incinerator Ash
- Gully waste
- C&D and C&I Waste
- Aggregate
- Skip Waste



**Ecohog HQ**  
Quarry Road | Carrickmore  
Omagh | Co. Tyrone | N.I.  
T (UK) +44 (0)28 8076 1295  
info@ecohog.com  
ecohog.com

# TECHNICAL DATA

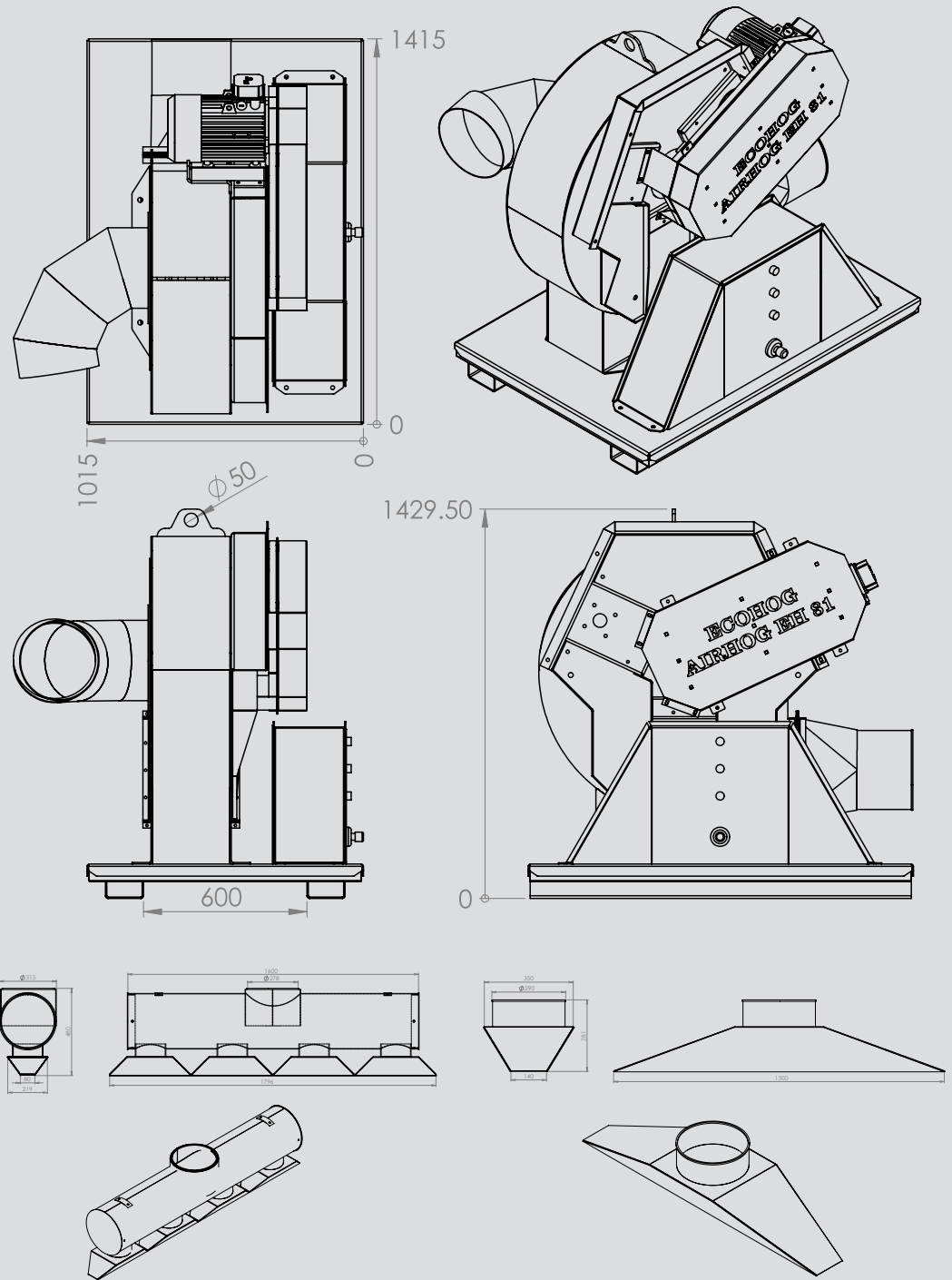

Please note: design and specification may be subject to change.

## SPECIFICATION

### EH-81 Airhog

Weight | 800kg (approx.)  
Version: Electric

Length (1415mm)  
Width (1050mm)  
Height (1430mm)  
Fan speed (1450rpm)

### Power Supply

11kW IP55 geared motors VSD

### Electrical Lockout

Key switch, engine protection system

### Hood Options

Suitable for 1.5m belt

Length (1300mm)  
Width (350mm)  
Height (280mm)

**HOODS CAN BE ADAPTED  
TO SUIT REQUIREMENTS UP  
TO 1.5M BELT LENGTH**

### Discharge Containment

5m ducting or Filter Sock

### UL Certifications

All products supplied by Ecohog will be built to the highest specification and control panels will be UL Approved for the USA and Canadian markets.

