



BULK HANDLING SOLUTIONS

Product Overview



REDUCED COST



**SITE OPERATING
EFFICIENCY**



**ENVIRONMENTAL
CONSIDERATIONS**



**IMPROVE HEALTH
& SAFETY**



**PRODUCT
QUALITY**

CONTENTS

Industries & Applications	3		
Telson™ Telescopic Conveyors		Ranger™ Tracked Conveyors	
Telson™ 42 Telescopic Conveyor	5	Ranger™ 5-21T Tracked Conveyor	22
Telson™ 46 Telescopic Conveyor	6	Ranger™ 5-24T Tracked Conveyor	23
Telson™ 52 Telescopic Conveyor	7	Ranger™ 6-24TR Radial Tracked Conveyor	24
Telson™ 58 Telescopic Conveyor	8	Ranger™ 24-RS Wheeled Radial Conveyor	25
		Ranger™ 6-31T Tracked Conveyor	26
Hornet™ Bulk Reception Feeders		Ranger™ Tracked Feeders	
Hornet™ 10-12 Bulk Reception Feeder	10	Ranger™ 4-15L Low Level Feeder	28
Hornet™ 15-18 Bulk Reception Feeder	11	Ranger™ 4-15H High Level Feeder	29
		Ranger™ 6-24H High Level Feeder	30
Manta™ Port Hoppers		Ranger™ 6-24L Low Level Feeder	31
Manta™ 60 Port Unloading Equipment	13	Ranger™ 6-24LS Orbital Feeder	32
Manta™ 70 Port Unloading Equipment	14	Ranger™ 6-24HS Orbital Feeder	33
Manta™ 75 Port Unloading Equipment	15	Ranger™ 6-24HO Orbital Organic Feeder	34
Manta™ 67 Port Unloading Equipment	16	Ranger™ 6-24HSO Orbital Organic Feeder	35
Manta™ 67HD Port Unloading Equipment	17	Ranger™ 6-27H High Level Feeder	36
Manta™ 63HD Port Unloading Equipment	18		
Manta™ 63HD-ECO Port Unloading Equipment	19		

Industries and Applications

A high level of versatility and a wide range of customisation options means that ProStack equipment can be used in many industries and applications. Our products are ideally suited for use in ports and terminals, quarrying and aggregates and mining and mineral industries, but can be adapted to suit many other applications.

Both mobile and stationary specifications are available for ProStack equipment along with a host of other customising options to suit your project. ProStack offer a comprehensive portfolio of products to address the needs of the bulk material handling and stockpiling markets.



Quarry and Aggregates

ProStack's expertly engineered conveyors are designed for quarry and aggregate applications. Often used for stockpiling and linking, these aggregate conveyors reduce the need for double handling, increase productivity/efficiency and reduce the reliance on traditional high cost stockpiling techniques including front-end wheel loaders.



Mining and Minerals

The ProStack range of bulk material handling solutions has been designed to convey large capacities of minerals and bulk materials for the mining industry. This reliability and efficiency allows for reduced levels of in-pit haulage, as a mobile mining conveyor system can transport the materials out of the pit to be stockpiled above ground. Less vehicles are then required on site which reduces fuel consumption and increases safety. From blast face to berth load out materials are moved safely and effectively.



Ports & Terminals

ProStack has an extensive suite of mobile equipment to suit every port and terminal application. A diverse range of port hoppers, mobile telescopic conveyors, bulk reception feeders and tracked conveyors ensure operational flexibility along with excellent technical performance as port loading conveyors.

Key Applications

The versatility of our products allow us to cater for a number of applications, including:



Stockpiling



Ship Loading &
Unloading



Heap
Leaching



Rail Loading &
Unloading



Port &
Terminals



Mining



Telson

Telescopic Conveyor Series



Telson™ 42 TELESCOPIC CONVEYOR

The Telson™ 42 Radial telescopic conveyor has a working length of 42 metres (140'), 270° of radial movement and is available in multiple tonnage options - 0-2000tph. Available in pit portable or road towable variants, the Telson 42 is a high quality machine suitable for almost all applications including ports and terminals and quarry and aggregate applications. Features include a fully electric drive, allowing the machine to be run from site electric or from an electric crusher, reducing machine maintenance. Automated stockpile patterns can be generated, reducing segregation, degradation, contamination and compaction, ensuring the correct specification for any application or industry. The machine also has a lattice design for increased strength while reducing the total weight. The pit portable version has multi-functional wheels which can be repositioned to perform the radial function. The road towable version allows the machine to be towed on the road in countries where it is permitted.

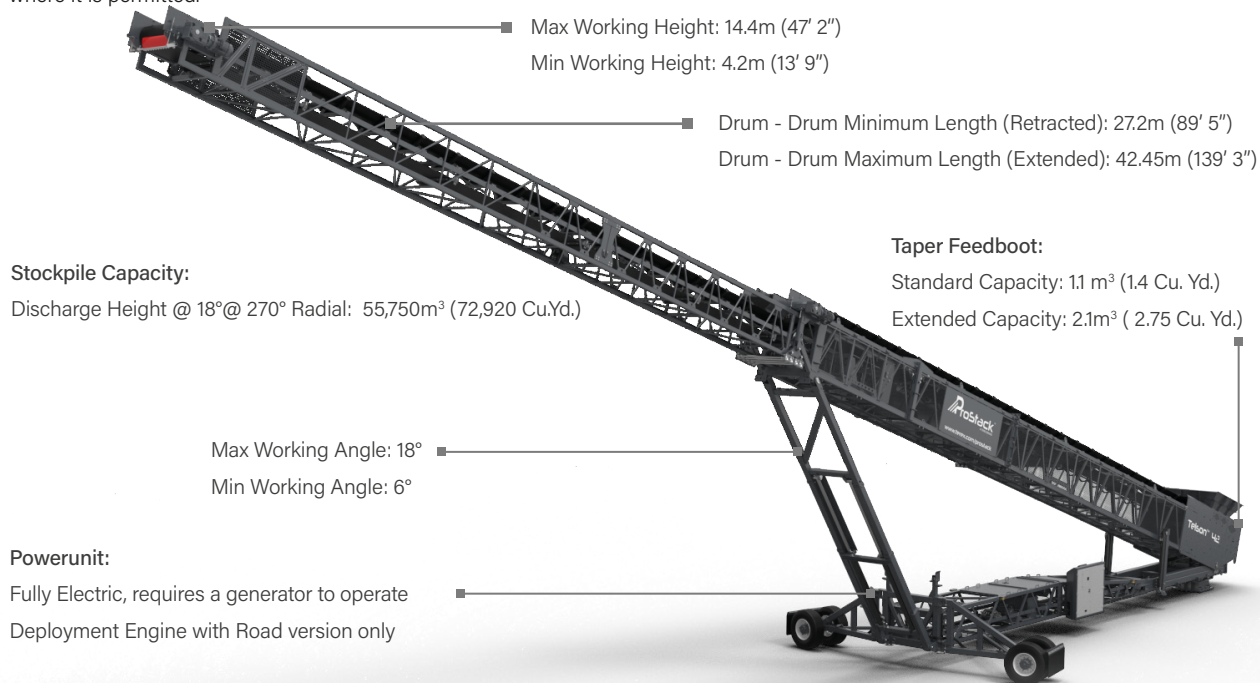

TRANSPORT DIMENSIONS	Telson™ 42
	PIT PORTABLE
Length	27.79m (91' 2")
Width	3.28m (10'9")
Height	5.19m (17')
Weight (Est.)	27,000kg (59,525 lbs)
Containerised shipping	3 x 40ft High Cube

CONVEYOR DETAILS	Telson™ 42
Conveyor length	42.45m (139'3")
Belt width	900mm (36")
Min. discharge height	4.2m (13'9")
Max. discharge height	14.4m (47'2")
Production capacity	0-2000tph (2204 stph)

AS4324.1 Structural Design as Standard

* Refer to order form for current listing of options available.

OPTIONS*
Throughputs between 0-2000 tph
Belt weigher
Pull cord E-Stop
Feedboot Lined 6mm steel liner
Feedboot Lined 6mm Wear plate
Feedboot Lined 12mm Wear plate
Feedboot Lined 20mm rubber
Chevron Belt
Heavy Duty Belt
Working Lights
Twin Radial Drive
Low level greasing for both conveyors
Belt alignment switches
Material sensors
Radial travel safety switches
Self aligning roller

OPTIONS Continued*
AS3000 Electrical
Self Aligning Tracking Roller
LED Work Lighting
Self Propelled Tracked Tugger
Dust Covers, Inner & Outer Conveyor
Single or Dual Sided Maintenance Catwalks
Road towable version available



Showing: Road towable version available

Telson™ 46 TELESCOPIC CONVEYOR

ProStack's Telson 46 Radial Telescopic Conveyor features a working length of 46 meters (150') and is capable of 270° of radial movement. Through close collaboration between the customer and ProStack's engineering team, the Telson 46 can be tailored to meet the specifications of multiple applications, including quarrying, ship loading and mining. The Telson 46 has a transport length of 31.4 metres (103') and is available in a road towable version in some territories.

A stockpile height of over 15 metres (49' 5") allows for a maximum stockpile capacity of approximately 138,190 tonnes.



TRANSPORT DIMENSIONS	Telson™ 46	OPTIONS*	OPTIONS Continued*
	ROAD TOWABLE	Throughputs between 0-2000 tph	Self Aligning Tracking Roller
Length	27.3m length (89'5")	Belt weigher	LED Work Lighting
Width	3.65m (11'9")	Pull cord E-Stop	Self Propelled Tracked Tugger
Height	4.2m (13'7")	Feedboot Lined 6mm steel liner	Dust Covers, Inner & Outer Conveyor
Weight (Est.)	29500 kg - 65000lbs	Feedboot Lined 6mm Wear plate	Single or Dual Sided Maintenance Catwalks
		Feedboot Lined 12mm Wear plate	
		Feedboot Lined 20mm rubber	
		Chevron Belt	
		Heavy Duty Belt	
		Working Lights	
		Twin Radial Drive	
		Low level greasing for both conveyors	
		Belt alignment switches	
		Material sensors	
		Radial travel safety switches	
		Self aligning roller	
CONVEYOR DETAILS	Telson™ 46		
Conveyor length	46m (150')		
Belt width	900mm (36")		
Min. discharge height	4.2m (13'9")		
Max. discharge height	15.1m (49'5")		
Production capacity	0-2000tph (2204 stph)		
AS43241 Structural Design as Standard			

* Refer to order form for current listing of options available.

Telson™ 52 TELESCOPIC CONVEYOR

The Telson™ 52 radial telescopic conveyor has a working length of 52 metres (170') and can be tailored to meet our customer's needs. A transport length of 34.2 metres (112') makes this a highly portable radial stacker conveyor. Capable of 270° of radial movement and a max working angle of 20° to allow for maximum stockpile capacity.

With a stockpile height of 18 metres (59') and maximum stockpile capacity of 182,176 tonnes the Telson 52 radial telescopic conveyor provides a heavy-duty solution to bulk material handling

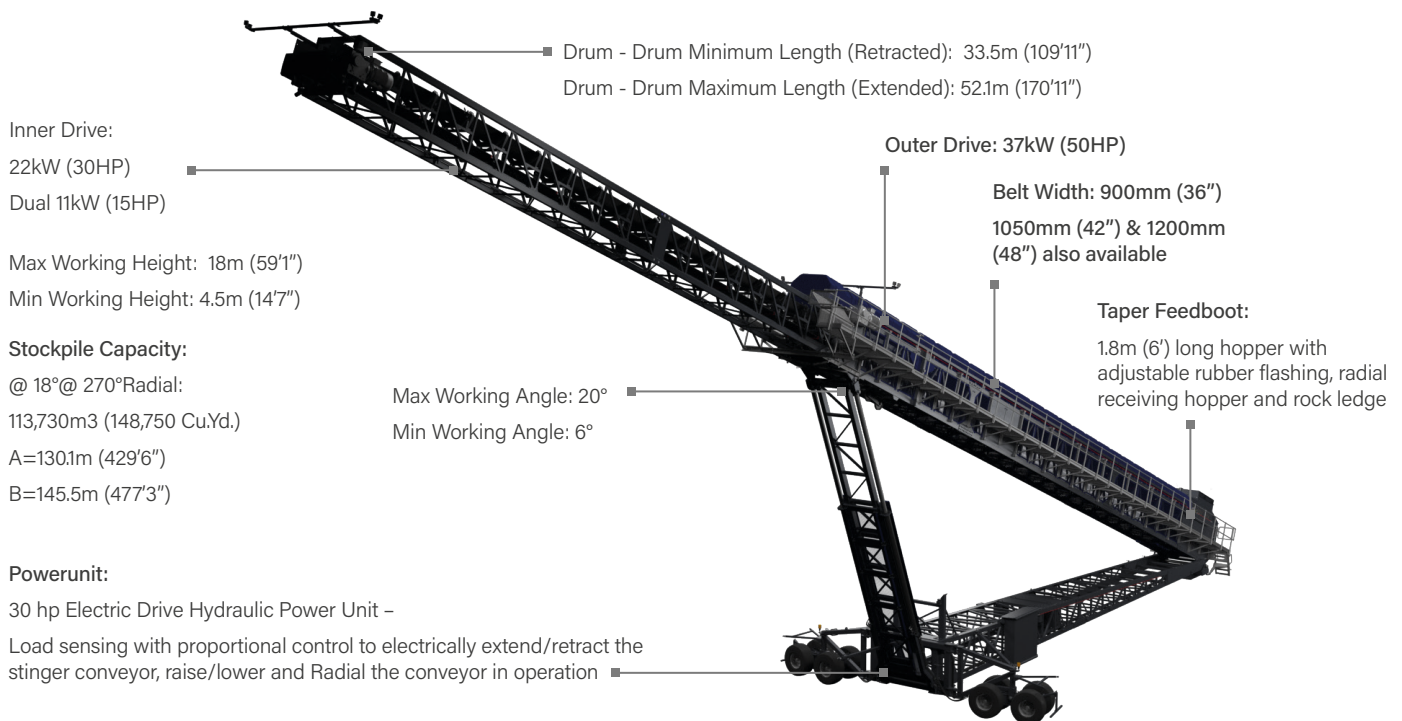

TRANSPORT DIMENSIONS	Telson™ 52	OPTIONS*	OPTIONS Continued*
Length	34m (111' 7")	Throughputs between 0-2000 tph	AS3000 Electrical
Width	3.6m (11'10")	Belt weigher	Self Aligning Tracking Roller
Height	4.6m (15')	Pull cord E-Stop	LED Work Lighting
Weight (Est.)	29,529kg (65,100 lbs) - 38,510kg (84,900lbs)	Feedboot Lined 6mm steel liner	Self Propelled Tracked Tugger
Containerised shipping	5 x 40ft High Cube	Feedboot Lined 6mm Wear plate	Dust Covers, Inner & Outer Conveyor
		Feedboot Lined 12mm Wear plate	Single or Dual Sided Maintenance Catwalks
		Feedboot Lined 20mm rubber	Road towable version available
		Chevron Belt	
		Heavy Duty Belt	
		Working Lights	
		Twin Radial Drive	
		Low level greasing for both conveyors	
		Belt alignment switches	
		Material sensors	
		Radial travel safety switches	
		Self aligning roller	
CONVEYOR DETAILS	Telson™ 52		
Conveyor length	52m (170'6")		
Belt width	900mm (36")		
Min. discharge height	4.5m (14'7")		
Max. discharge height	18.5m (60'7")		
Production capacity	0-2000tph (2204 stph)		

DIFFERENT CAPABILITIES OF TPH ARE AVAILABLE

* Refer to order form for current listing of options available.

Telson™ 58 TELESCOPIC CONVEYOR

The Telson™ 58 radial telescopic conveyor has a working length of 58 metres (190') and can be tailored to meet our customer's needs. A transport length of 34.2 metres (112') makes this a highly portable radial stacker conveyor. Capable of 270° of radial movement and a max working angle of 18° to allow for maximum stockpile capacity.

With a stockpile height of 20 metres (65') and maximum stockpile capacity of 237,943 tonnes the Telson™ 58 radial telescopic conveyor provides a heavy-duty solution to bulk material handling.

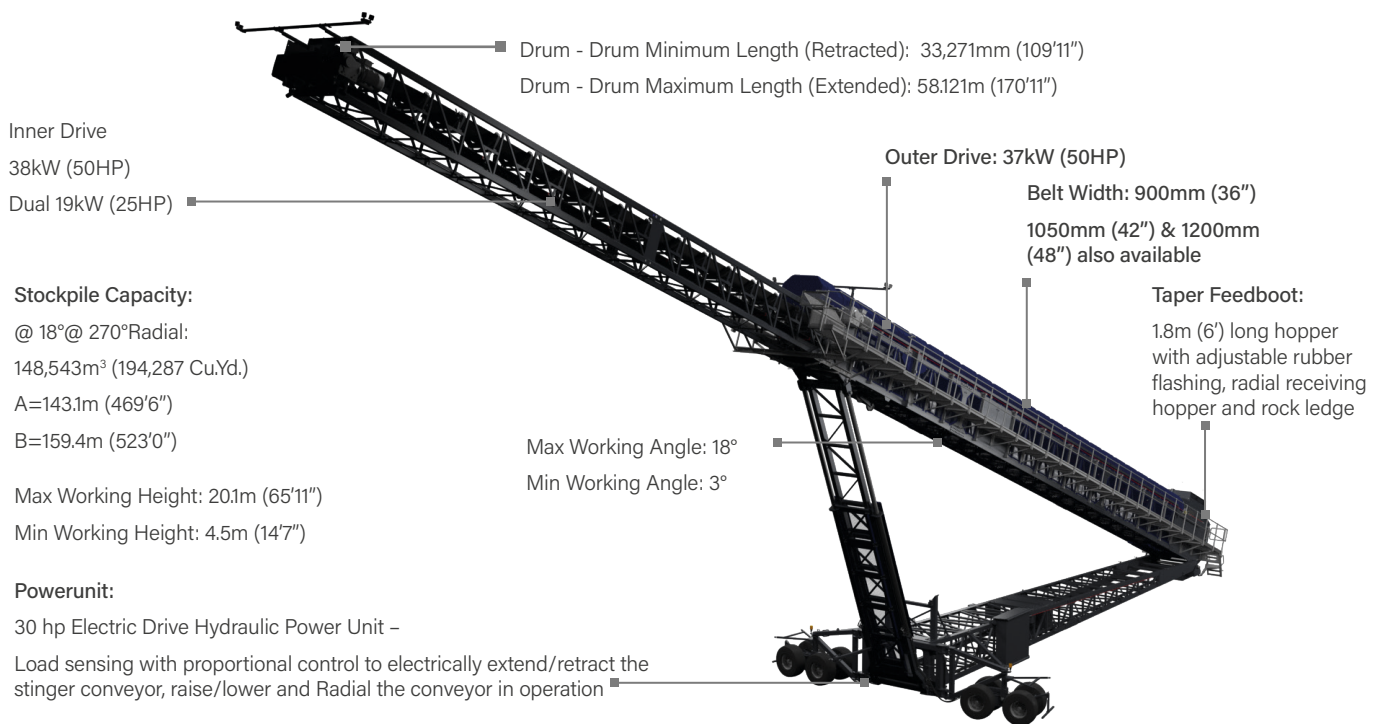

Stockpile Capacity:

@ 18°@ 270°Radial:
148,543m³ (194,287 Cu.Yd.)
A=143.1m (469'6")
B=159.4m (523'0")

Max Working Height: 20.1m (65'11")
Min Working Height: 4.5m (14'7")

Powerunit:

30 hp Electric Drive Hydraulic Power Unit –
Load sensing with proportional control to electrically extend/retract the stinger conveyor, raise/lower and Radial the conveyor in operation

TRANSPORT DIMENSIONS	Telson™ 58	OPTIONS*	OPTIONS Continued*
Length	34.124m (112')	Dual power travel	AS3000 Electrical
Width	3.6m (11'10")	Material sensor	Self Aligning Tracking Roller
Height	4.6m (15")	Belt scraper upgrade	LED Work Lighting
Weight (Est.)	37,988kg (83,750 lbs) - 38,125kg (84,050 lbs)	Spray Bar	Self Propelled Tracked Tugger
Containerised shipping	7 x 40ft High Cube	Automation package	Dust Covers, Inner & Outer Conveyor
		Lead chord for Panel	Single or Dual Sided Maintenance Catwalks
		On board counterweight	Road towable version available
		Impact Idlers	
		Safety Switch	
		Hydraulic Oil Tank Heater	
		Heater and fan for electrical panel	
		Automatic Lubrication system	
		Wireless remote control	
		Hydraulic axle jacking legs	
		Dust covers	
		Telematics	
		Walkways	

* Refer to order form for current listing of options available.



Hornet

Bulk Reception Feeder Series



HORNET™ 10-12

BULK RECEPTION FEEDER

The Hornet™ 10-12 mobile bulk reception feeder has a 45 foot long and 48 inches wide conveyor belt for high capacity material handling. A number of customising options are available so that the Hornet 10-12 can meet the demands of any material handling applications. Static or wheeled options are available.

The Hornet™ series is purpose built to accept load from rear tip, articulated and belly feed trucks. Allowing the port operation to tip directly into conveyor rather than on the quayside allows for truck-to-ship loading. Throughout the process, the Hornet series can either be used to load directly into vessel or more commonly be used to directly feed larger ProStack shiploading equipment.

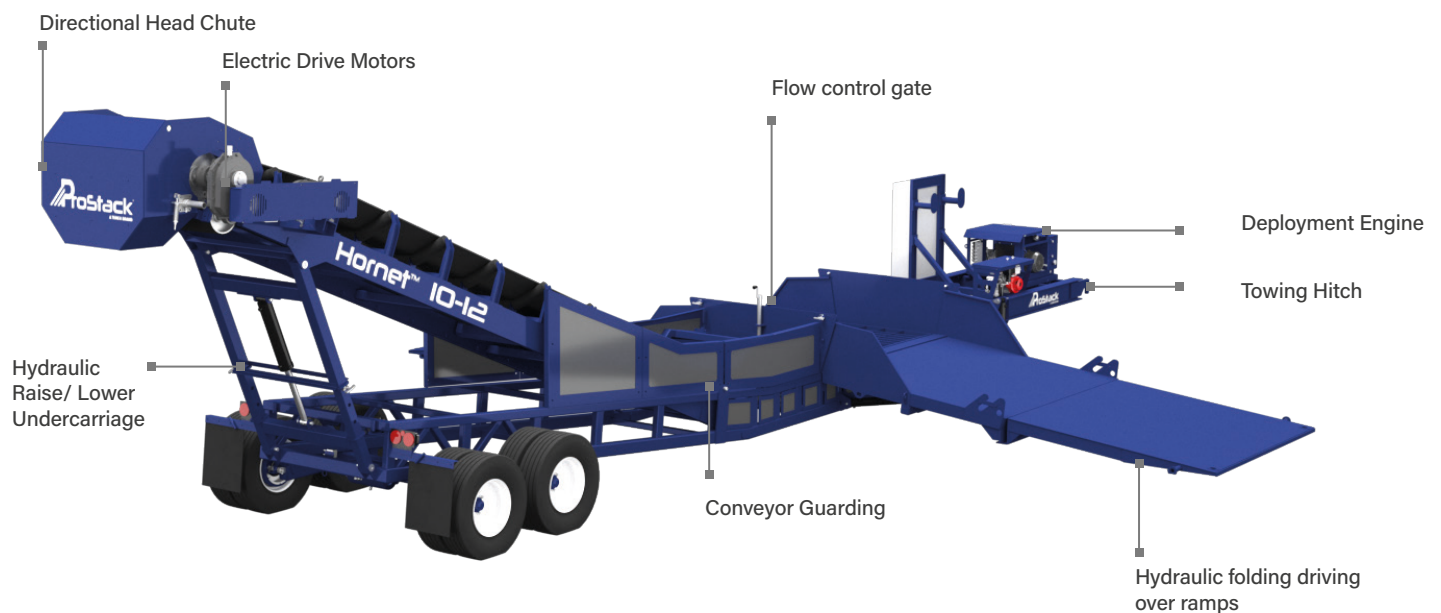

TRANSPORT DIMENSIONS	Hornet™ 10-12
Length	19.5m (64' 1")
Width	3.65m (11' 12")
Height	4m (13' 1")
Weight (Est.)	19280kg (42,500lb)
Containerised shipping	3 x 40ft High Cube

CONVEYOR DETAILS	Hornet™ 10-12
Conveyor length	13.7m (45')
Belt width	1200mm (48")
Min. Discharge height	3.1m (10' 2") @16 deg
Max. discharge height	4.1m (13' 5") @ 23 deg
Production capacity	1000TPH @1600kg m ³ (1100 STPH)

OPTIONS
Hydraulic Landing Jacks and Power Unit
Wireless Remote-Control System
Additional Remote
Vulcanized Belt Splice
Central Automated Lubrication System
Continuous Cycling Ramps & Hot Climate Hydraulic Protection
Cold Weather Hydraulic Oil Tank Heater
Walkway over Belt - with stairs
Onboard Genset- 250KW Genset to power Hornet & Telson
Feed Hopper- 17 cubic yard Integrated reception Hopper
Containerization - break down and pack into 3 containers

HORNET™ 15-18

BULK RECEPTION FEEDER

The Hornet™ 15-18 Portable Bulk Reception Feeder has a 56 foot long and 72 inches wide conveyor belt and is built to handle the toughest jobs. This Heavy Duty Bulk Reception Feeder allows for the highest level of productivity and efficiency for loading and unloading trucks, ships, trains and more.

The Hornet series is purpose built to accept load from rear tip, articulated and belly feed trucks. Allowing the port operation to tip directly into conveyor rather than on the quayside allows for truck-to-ship loading. Throughout the process, the Hornet series can either be used to load directly into vessel or more commonly be used to directly feed larger ProStack shiploading equipment.

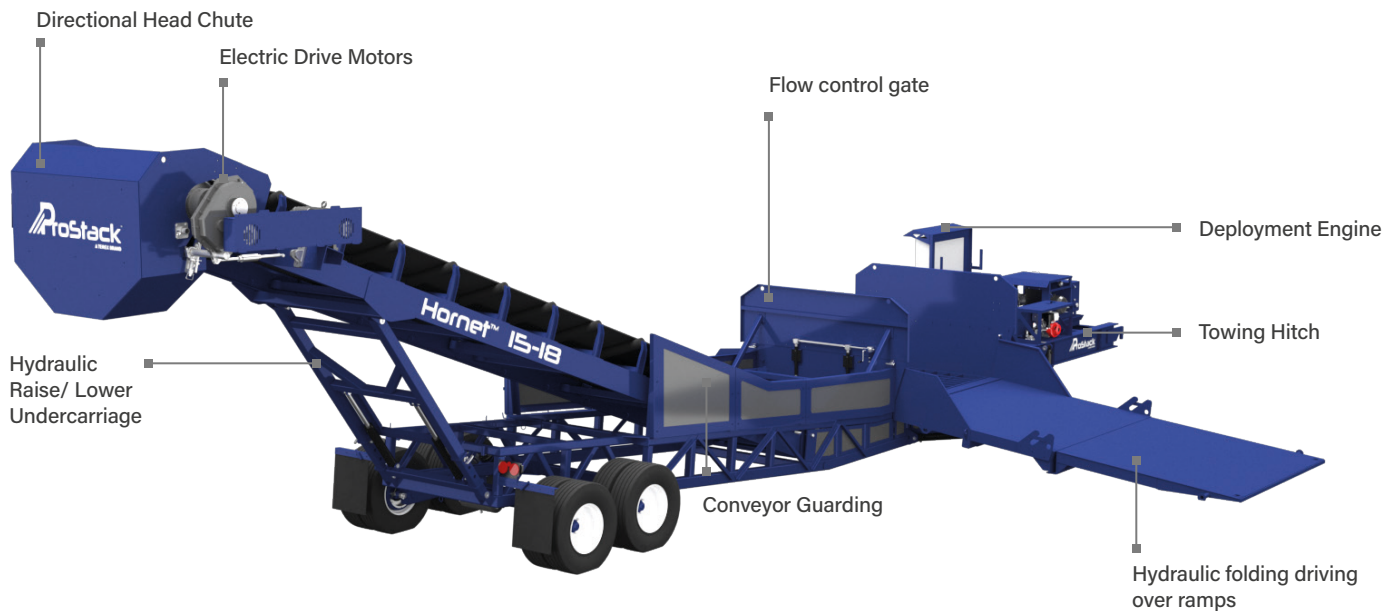

TRANSPORT DIMENSIONS	Hornet™ 15-18
Length	21.65m (71')
Width	3.65m (11' 12")
Height	4m (13' 1")
Weight (Est.)	23950kg (52,700lb)
Containerised shipping	4 x 40ft High Cube

CONVEYOR DETAILS	Hornet™ 15-18
Conveyor length	17m (56')
Belt width	1800mm (72")
Min. Discharge height	3.52m (11' 6") @15 deg
Max. discharge height	4.66m (15' 3") @ 21 deg
Production capacity	1500 TPH @1600kg m ³ (1650 STPH)

OPTIONS
Hydraulic Landing Jacks and Power Unit
Wireless Remote-Control System
Additional Remote
Vulcanized Belt Splice
Central Automated Lubrication System
Continuous Cycling Ramps & Hot Climate Hydraulic Protection
Cold Weather Hydraulic Oil Tank Heater
Walkway over Belt - with stairs
Onboard Genset- 250KW Genset to power Hornet & Telson
Feed Hopper- 17 cubic yard Integrated reception Hopper
Containerization - break down and pack into 3 containers

ProStack
Bulk Handling Solutions



Port Hopper Series



Manta™ 60

PORT UNLOADING EQUIPMENT

The Manta™ 60 Port Hopper has a Material Density Range of 0.5 to 1.2. It comes in an in-line tow chassis configuration with a removable tow bar. It is suitable for applications with restricted quay widths.

Loaded with a crane and grab, Manta hoppers are a robust, reliable and efficient bulk handling solutions - customized to the product, terminal and specifications of our clients.

Features:

- ✓ Ease of use
- ✓ Robust
- ✓ Torsionally stiff frame
- ✓ Patented load equalizing suspension
- ✓ High quality steel
- ✓ Flexible material handling

Overview

Hopper Aperture	6m x 6m
Machine height	9m
Hopper capacity	50m³ (Below Grid)
Mobility	Detachable Tow bar
Discharge	Hydraulic Slide
Power	Plug in & Onboard Genset
Material Density Range	0.5 to 1.2

Standard Specifications

33 KVA Generator
Single hydraulic 500mm slide
Hydraulic Wheel jacking
Operator cabin with Joystick Control
Access Ladder to Thimble
Out-Loading Rubber Chute
Detachable 5th wheel lift point
Travel Beacon and Siren
Machine Quayside Lighting
One Colour Paint Scheme
LD Trash Grid (200x200 Aperture)



Image shown

In-line Tow Chassis configuration

Removable Tow bar Suitable for applications with restricted Quay widths

Options

Single hydraulic 700mm slide upgrade
Air conditioning unit
FM Radio
Port Operators radio - Pedal Operated
Thimble Wash down Line
Towing Light System
Floodlight Quayside lighting
Client Colour Scheme
Traffic Light System
Tannoy System
HD Trash Grid 300x300 aperture
HD Trash Grid 350x350 aperture
Cable Reel

Manta™ 70

PORT UNLOADING EQUIPMENT

The Manta™ 70 Port Hopper has a Material Density Range of 0.5 to 1.2. It comes with an in-line tow chassis configuration and a removable tow bar. It is suitable for applications with restricted quay widths.

Loaded with a crane and grab, Manta hoppers are a robust, reliable and efficient bulk handling solutions - customized to the product, terminal and specifications of our clients.

Features:

- ✓ Ease of use
- ✓ Robust
- ✓ Torsionally stiff frame
- ✓ Patented load equalizing suspension
- ✓ High quality steel
- ✓ Flexible material handling

Overview

Hopper Aperture	7m x 7m
Machine height	9.5m
Hopper capacity	60m³ (Below Grid)
Mobility	Detachable Tow bar
Discharge	Hydraulic Slide
Power	Plug in & Onboard Genset
Material Density Range	0.5 to 1.2

Standard Specifications

33 KVA Generator
Single hydraulic 500mm slide
Hydraulic Wheel jacking
Operator cabin with Joystick Control
Access Ladder to Thimble
Out-Loading Rubber Chute
Detachable 5th wheel lift point
Travel Beacon and Siren
Machine Quayside Lighting
One Colour Paint Scheme
LD Trash Grid (200x200 Aperture)



Image shown

In-line Tow Chassis configuration

Removable Tow bar Suitable for applications with restricted Quay widths

Options

Single hydraulic 700mm slide upgrade
Air conditioning unit
FM Radio
Port Operators radio - Pedal Operated
Thimble Wash down Line
Towing Light System
Floodlight Quayside lighting
Client Colour Scheme
Traffic Light System
Tannoy System
HD Trash Grid 300x300 aperture
HD Trash Grid 350x350 aperture
Cable Reel

Manta™ 75

PORT UNLOADING EQUIPMENT

The Manta™ 75 Port Hopper has a Material Density Range of 0.5 to 1.0. It comes with a fixed tow chassis configuration.

Loaded with a crane and grab, Manta hoppers are a robust, reliable and efficient bulk handling solutions - customized to the product, terminal and specifications of our clients.

Features:

- ✓ Ease of use
- ✓ Robust
- ✓ Torsionally stiff frame
- ✓ Patented load equalizing suspension
- ✓ High quality steel
- ✓ Flexible material handling



*Image shown
Fixed Tow Chassis configuration*

Overview

Hopper Aperture	7.5m x 7.5m
Machine height	9.570m
Hopper capacity	60m ³ (Below Grid)
Mobility	Fixed Towable
Discharge	Hydraulic Slide
Power	Plug in & Onboard Genset
Material Density Range	0.5 to 1.0

Standard Specifications

33 KVA Generator
Single hydraulic 500mm slide
Hydraulic Wheel jacking
Operator cabin with Joystick Control
Access Ladder to Thimble
Out-Loading Rubber Chute
Detachable 5th wheel lift point
Travel Beacon and Siren
Machine Quayside Lighting
One Colour Paint Scheme
LD Trash Grid (200x200 Aperture)

Options

Air conditioning unit
Hydraulic operated slide upgrade (Based on Spec)
FM Radio
Port Operators radio - Pedal Operated
Thimble Wash down Line
Towing Light System
Floodlight Quayside lighting
Client Colour Scheme
Traffic Light System
Tannoy System
LD Trash grid upgrade
Cable Reel
Flex Flap System

Manta™ 67

PORT UNLOADING EQUIPMENT

The Manta™ 67 Port Hopper has a Material Density Range of 0.5 to 1.5. It comes with a fixed tow chassis configuration.

Loaded with a crane and grab, Manta hoppers are a robust, reliable and efficient bulk handling solutions - customized to the product, terminal and specifications of our clients.

Features:

- ✓ Ease of use
- ✓ Robust
- ✓ Torsionally stiff frame
- ✓ Patented load equalizing suspension
- ✓ High quality steel
- ✓ Flexible material handling



Overview

Hopper Aperture	6.7m x 6.7m
Machine height	8.896m
Hopper capacity	61.3m³ (Below Grid)
Mobility	Fixed Towable
Discharge	Hydraulic Slide
Power	Plug in & Onboard Genset
Material Density Range	0.5 to 1.0

Standard Specifications

33 KVA Generator
Single hydraulic 500mm slide
Hydraulic Wheel jacking
Operator cabin with Joystick Control
Access Ladder to Thimble
Out-Loading Rubber Chute
Fixed 5th wheel lift point
Travel Beacon and Siren
Machine Quayside Lighting
One Colour Paint Scheme
HD Trash Grid 300x300 aperture

Image shown

In-line Tow Chassis configuration

Removable Tow bar Suitable for applications with restricted Quay widths

Options

Single hydraulic 700mm slide upgrade
Air conditioning unit
FM Radio
Port Operators radio - Pedal Operated
Thimble Wash down Line
Towing Light System
Floodlight Quayside lighting
Client Colour Scheme
Traffic Light System
Tannoy System
LD Trash grid upgrade
Cable Reel

Manta™ 67HD

PORT UNLOADING EQUIPMENT

The Manta™ 67HD Port Hopper has a Material Density Range of 0.75 to 1.6. It comes with a tow chassis configuration and there is a self drive and Flex-Flap system upgrade available.

Loaded with a crane and grab, Manta hoppers are a robust, reliable and efficient bulk handling solutions - customized to the product, terminal and specifications of our clients.

Features:

- ✓ Ease of use
- ✓ Robust
- ✓ Torsionally stiff frame
- ✓ Patented load equalizing suspension
- ✓ High quality steel
- ✓ Flexible material handling



Overview

Hopper Aperture	6.7m x 6.7m
Machine height	10,028m
Hopper capacity	60m ³ (Below Grid)
Mobility	Fixed Towable (Self Drive Option)
Discharge	Hydraulic Slide
Power	Plug in & Onboard Genset
Material Density Range	0.75 to 1.6

Standard Specifications

33 KVA Generator
Single hydraulic 700mm slide
Hydraulic Wheel jacking
Operator cabin with Joystick Control
Air conditioning unit
Access Ladder to Thimble
Out-Loading Rubber Chute
5th wheel lift point
Travel Beacon and Siren
Machine Quayside Lighting
One Colour Paint Scheme
HD Trash Grid (300x300 Aperture)

Image shown

Tow Chassis configuration

Self Drive and Flex-Flap system upgrade available

Options

Hydraulic operated slide upgrade (Based on Spec)
FM Radio
Port Operators radio - Pedal Operated
Thimble Wash down Line
Self Drive Up-Grade
Towing Light System
Floodlight Quayside lighting
Client Colour Scheme (Based on Spec)
Traffic Light System
Tannoy System
HD Trash grid 350x350 aperture
Flex Flap System
Cable Reel

Manta™ 63HD

PORT UNLOADING EQUIPMENT

The Manta™ 63HD Port Hopper is the largest in the standard range and has a Material Density Range of 0.75 to 1.8. It has a hopper capacity of up to 80m³ and a height of 13.6m.

Loaded with a crane and grab, Manta hoppers are a robust, reliable and efficient bulk handling solutions - customized to the product, terminal and specifications of our clients.

Features:

- ✓ Ease of use
- ✓ Robust
- ✓ Torsionally stiff frame
- ✓ Patented load equalizing suspension
- ✓ High quality steel
- ✓ Flexible material handling

Overview

Hopper Aperture	6.3m x 6.3m
Machine height	13,600m
Hopper capacity	60m ³ (with Filtration) 80m ³ (with Filtration)
Mobility	Self Drive
Discharge	Hydraulic Slide
Power	Plug in & Onboard Genset
Material Density Range	0.75 to 1.8

Standard Specifications

110 KVA Generator
Twin hydraulic 500mm slide
Hydraulic Wheel jacking
Operator cabin with Joystick Control
Air conditioning unit
Access Ladder to Thimble
Thimble wash down lines
Out-Loading Rubber Chute
Self Drive
Travel Beacon and Siren
Machine Quayside Lighting
One Colour Paint Scheme
HD Trash Grid (300x300 Aperture)
Flex Flap System



Image shown

Fitted with Dual Hopper Outlet

Options

Single hydraulic 700mm slide (replaces 500mm Slide)
Air conditioning unit
FM Radio
Port Operators radio - Pedal Operated
Thimble Wash down Line
Towing Light System
Floodlight Quayside lighting
Client Colour Scheme
Traffic Light System
Tannoy System
HD Trash Grid 300x300 aperture
HD Trash Grid 350x350 aperture
Cable Reel

Manta™ 63HD-ECO

PORT UNLOADING EQUIPMENT

The Manta 63HD-ECO Environmental Port Hopper is the largest of the standard range and has a Material Density Range of 0.75 to 1.8. It has a hopper capacity of up to 80m³ and a height of 13.6m. A full dust encapsulation filtration systems ensures a clean and healthy environment during operation.

Loaded with a crane and grab, Manta hoppers are a robust, reliable and efficient bulk handling solutions - customized to the product, terminal and specifications of our clients.

Features:

- ✓ Ease of use
- ✓ Robust
- ✓ Torsionally stiff frame
- ✓ Patented load equalizing suspension
- ✓ High quality steel
- ✓ Flexible material handling

Overview

Hopper Aperture	6.3m x 6.3m
Machine height	13,600m
Hopper capacity	60m ³ (with Filtration) 80m ³ (with Filtration)
Mobility	Self Drive
Discharge	Hydraulic Slide
Power	Plug in & Onboard Genset
Material Density Range	0.75 to 1.8

Standard Specifications

110 KVA Generator
Twin hydraulic 500mm slide
Hydraulic Wheel jacking
Operator cabin with Joystick Control
Air conditioning unit
Access Ladder to Thimble
Thimble wash down lines
Out-Loading Rubber Chute
Self Drive
Travel Beacon and Siren
Machine Quayside Lighting
One Colour Paint Scheme
HD Trash Grid (300x300 Aperture)
Flex Flap System
Aspirated Dust Control Filters
Reverse jet Filter Clening



*Image shown
Fitted with Dual Hopper Outlet
Aspirated dust control Filters*

Options

Twin Hydraulic operated Slide Upgrade to 700mm
FM Radio
Port Operators radio - Pedal Operated
Out-Loading retractable Bellows
Floodlight Quayside lighting
Client Colour Scheme (Based on spec)
Traffic Light System
Tannoy System
HD Trash Grid 350x350 aperture upgrade
Aspirated Dust Control Filters (Based on Product)
Reverse Jet Filter Cleaning System (Based on Product)
Cable Reel



TAILOR MADE SOLUTIONS

From our small standard range up to our large rail mounted multiple discharge configurations, you will get the right solution for you.

“ We Will Work With You to Develop a Cost-Effective, 'Fit For Purpose' Ship-Unloader For Your Port ”



Ranger

Tracked Conveyor
Series



Ranger™ 5-21T & Ranger™ 5-24T TRACKED CONVEYORS

The ProStack Ranger™ series is made up of tracked conveyors in both high level and low level specifications. Heavy duty tracks as standard make these conveyors highly portable and versatile enough for many different applications. Each machine is easily transported while select models feature rotating undercarriages. Using conveyors means increased stockpile capacity and reduced on-site material handling. For convenience and to keep shipping costs low, Prostack conveyors can be transported in a 40ft container. The range includes 65ft and 80ft track mobile conveyors: Ranger™ 5-21T and Ranger™ 5-24T.

TRANSPORT DIMENSIONS	Ranger™ 5-21T	Ranger™ 5-24T
Length	11.3m (37')	11.88m (38' 11")
Width	2.25m (7' 4")	2.25m (7' 4")
Height	2.65m (8' 8")	2.88m (9' 5")
Weight (Est.)	13,820kgs (30,467lbs)	16,750kgs (36,927lbs)
Containerised shipping	1 x 40ft High Cube	1 x 40ft High Cube

CONVEYOR DETAILS	Ranger™ 5-21T	Ranger™ 5-24T
Conveyor length	19.79m (64' 11")	22.8m (74' 10")
Belt width	1050mm (42")	1050mm (42")
Discharge height	9.1m (29'10") @ 24°	9.9m (32' 5") @ 24°
Max. discharge height	9.45m (31') @ 28°	10.41m (34'11") @ 25°
Production capacity	Up to 500 TPH (551 US TPH)	Up to 500 TPH (551 US TPH)

OPTIONS*	Ranger™ 5-21T	Ranger™ 5-24T
Feedboot liners: AR400 plate or 20mm rubber	▪	▪
Feedboot extension with liners	▪	▪
Large capacity biomass hopper	▪	▪
Chevron belt	▪	▪
Twin hydraulic drive discharge conveyor	▪	▪
Aluminium dust covers	▪	▪
Spray bar at head drum	▪	▪
Full length skirting rubber	▪	▪
Overband magnet with hydraulic kit and support frames	▪	▪
Hybrid complete with hydraulic and electric conveyor drive (400 TPH)	▪	▪
Twin Electric Drive 2 x 11kw motors (Hydraulic Conveyor Drive Removed) (400 tph)	▪	▪
Radio Remote to track machine	▪	▪

* Refer to order form for current listing of options available.

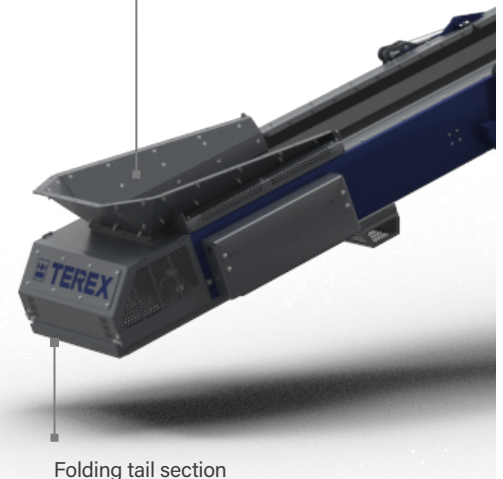

Folding tail section



Steel lined feedboot as standard providing extended wear life. Feedboot extensions and rubber lined options also available

Hydraulic angle adjustment for easy plant integration.
Hydraulic adjustment for variable feed height reduces impact and provides optimal material transfer.

Folding head section

Compact folding mechanism allows containerised shipping as one unit

Pinless deployment

Tier 3: Deutz DT011 36kW (45hp)
Stage V and Tier 4: Caterpillar C2.2 - 55kW (74hp)
Fuel tank volume 200L (58 US GAL)

Dual-speed tracks for quick and controlled deployment

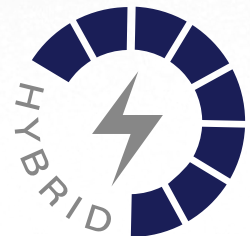

REDUCED COST



SITE OPERATING EFFICIENCY



ENVIRONMENTAL CONSIDERATIONS



IMPROVE HEALTH & SAFETY



PRODUCT QUALITY

Ranger™ 6-24TR

RADIAL TRACKED CONVEYOR

The Ranger™ 6-24TR tracked radial stockpiling conveyor is the ideal solution for stockpiling after mobile crushing and screening plants. The mobility and flexibility of the radial stockpiling conveyors reduces the use of a wheel loader on site. The conveyors ensure all applications are catered for from the easiest, right through to the hardest.



TRANSPORT DIMENSIONS	Ranger™ 6-24TR
Length	15.2m (49' 10")
Width	2.52m (8' 3")
Height	3.43m (11' 3")
Weight (Est.)	19,800kg (43,651lbs)

CONVEYOR DETAILS	Ranger™ 6-24TR
Conveyor length	22.9m (74' 10")
Belt width	1050mm (42")
Discharge height	9m (29' 6") @ 18°
Max. discharge height	10.9m (34' 9") @ 23°
Production capacity	Up to 600TPH (661 US TPH)

OPTIONS*
Feedboot liners: AR400 plate or 20mm rubber
Feedboot extension with liners
Impact bed at feedboot area
Anti-roll back flaps
Chevron belt
Heavy duty plain belt
Twin hydraulic drive discharge conveyor
High spec discharge conveyor head drum scraper
Dust hood
Canvas dust covers
Dust suppression water spray bar at head drum
Full length skirting rubber
Grease lines to head drum bearings on discharge conveyor
Belt weigher
Radio remote to stop/start, raise/lower conveyor
Radio Remote to track machine
Auto radial & raise function
Containerised freight

* Refer to order form for current listing of options available.

Ranger™ 24-RS

RADIAL WHEELED CONVEYOR

The Ranger™ 24-RS radial conveyor is designed to be one of the most cost efficient and effective ways of stockpiling material on the market. Available in either Pit or Road towable variants, the Ranger 24-RS offers a variety of different options which means it can meet the requirements of almost all applications. This simple but efficient radial conveyor is available in both electric and hydraulic drive systems and can be tailored to meet operator needs. Key applications include quarrying, aggregates and mining.



**SHOWING:
ROAD CHASSIS,
HYDRAULIC WITH CAT ENGINE**

TRANSPORT DIMENSIONS	Ranger™ 24-RS	
	ROAD TOWABLE	PIT PORTABLE
Length	16.17m (52' 11")	16.55m (54' 3")
Width	2.5m (8' 3")	3.1m (10' 2")
Height	3.36m (11')	3.95m (12' 11")
Weight (Est.) with full options	10,000kgs (22,046lbs)	
Containerised shipping	1 x 40ft Open Top High Cube (2 machines per container)	1 x 40ft Open Top High Cube (2 machines per container)

CONVEYOR DETAILS	Ranger™ 24-RS
Conveyor length	22.9m (74' 10")
Belt width	914mm (36")
Max. discharge height	9.2m (30' 1")
Production capacity	Up to 300TPH (330US TPH)

- OPTIONS***
- _____ Pull cord E-Stop
 - _____ Feedboot Lined 6mm wearplate
 - _____ Feedboot extensions
 - _____ Chevron Belt
 - _____ Heavy Duty Belt
 - _____ Conveyor underguard length of mid-section
 - _____ Canvas dust covers
 - _____ Hydraulic angle adjust
 - _____ Hydraulic fold over for transport
 - _____ Hydraulic axle jacking legs
 - _____ Single radial wheel drive

* Refer to order form for current listing of options available.

Ranger™ 6-31T TRACKED CONVEYOR

The Ranger™ 6-31T builds on the hugely successful ProStack Ranger™ 5-21T and Ranger™ 5-24T conveyors. The extra length of conveyor, and increased power, allows for maximum mobility and flexibility, reducing or eliminating the use of wheeled loaders on site. The conveyor can cope with all applications, from light duty screened material, through to jaw applications. The Conveyor is 100ft long and still retains the ability to be transported worldwide in a 40ft container.



TRANSPORT DIMENSIONS	Ranger™ 6-31T
Length	11.9m (39')
Width	2.84m (9'4")
Height	3.43m (11' 3")
Weight (Est.)	21,800kg (48,060lbs)
Containerised shipping	1 x 40ft High Cube

CONVEYOR DETAILS	Ranger™ 6-31T
Conveyor length	30.1m (98'9")
Belt width	1050mm (42")
Discharge height	10.1m (33' 1") @ 18°
Max. discharge height	13.1m (43' 11") @ 25°
Production capacity	Up to 600TPH (661 US TPH)

OPTIONS*
Feedboot liners: AR400 plate or 20mm rubber
Feedboot extension with liners
Impact bed at feedboot area
Anti-roll back flaps
Chevron belt
Heavy duty plain belt
Twin hydraulic drive discharge conveyor
High spec scraper on discharge conveyor at head drum
Dust hood
Canvas dust covers
Dust suppression water spray bar at head drum
Full length skirting rubber
Overband magnet with hydraulic kit and support frames
Grease lines to head drum bearings on discharge conveyor
Radio remote to track machine

* Refer to order form for current listing of options available.

** Contact factory for availability.

Ranger

Tracked Feeders Series



Ranger™ 4-15L

LOW LEVEL FEEDER

The ProStack's Ranger™ 4-15L Low Level Tracked Conveyor has a high level of portability and is suited to almost any working environment. The Ranger 4-15L can be fed from three sides, allowing the operator to have greater versatility when loading the hopper. Hopper extensions can be deployed via hydraulics with support arms fitted. This removes the need for manual bolting of the hopper, which enables a faster set up time. Operators will have an unregulated flow of material from the feeder, resulting in improved handling of difficult material and elimination of feeder blockages. An optional feed hopper outlet door is fully adjustable, allowing the operator to control the amount of material passing from the feed conveyor to the discharge conveyor.

Key applications include quarrying, aggregates, mining and ports.



TRANSPORT DIMENSIONS	Ranger™ 4-15L
Length	15.6m (51' 2")
Width	2.84m (9' 4")
Height	3.43m (11' 3")
Weight (Est.)	21,800kg (48,060lbs)
Containerised shipping	1 x 40ft High Cube

CONVEYOR DETAILS	Ranger™ 4-15L
Conveyor length	15.6m (51' 2")
Belt width	1050mm (42")
Max. discharge height	7.2m (23' 8")
Production capacity	Up to 450TPH (496 US TPH)

* Refer to order form for current listing of options available.

** Contact factory for availability.

OPTIONS*

- Adjustable feed hopper outlet door
- Integrated fall break system bolted into hopper with adjustable feed hopper outlet door
- Anti-Roll Back Flaps
- Chevron Belt on Discharge Conveyor
- Heavy Duty Plain Belt on Discharge Conveyor
- High Spec Scraper Discharge Conveyor at Head Drum
- Discharge Conveyor Underguard Length of Mid-Section
- Pull Cord E-Stop
- Dust Hood
- Canvas Dust Covers
- Spray Bar at Head Drum on Discharge Conveyor
- Full Length skirting rubber along Discharge Conveyor
- Belt Weigher
- Low Level Grease Lines to Head Drum
- Overband Magnet on Discharge Conveyor with Hydraulic Kit and Support Frames
- Radio Remote
- T-Link Telematics (Aftermarket Option)

Ranger™ 4-15H HIGH LEVEL FEEDER

The Ranger™ 4-15 High Level Feeder has a high level of portability and is suited to almost any working environment. Operators have the ability to stockpile directly from crushers, screens or other material source removing the need for double handling of material. This greatly reduces site traffic, labour and maintenance costs.

Key applications include quarrying, aggregates and mining.



TRANSPORT DIMENSIONS	Ranger™ 4-15H
Length	12.16m (39' 11")
Width	2.29m (7' 6")
Height	2.55m (8' 4")
Weight (Std.)	13,240kg (29189lbs)
Containerised shipping	1 x 40ft High Cube

CONVEYOR DETAILS	Ranger™ 4-15H
Conveyor length	15.6m (51'2").
Belt width	1050mm (42")
Max. discharge height	7.2m (23'8")
Production capacity	Up to 450 TPH (496 US TPH)

* Refer to order form for current listing of options available.

OPTIONS*

Hopper upgrade
12ft Single Deck vibrating grid
12ft Tipping Grid with 4', 5" or 6" Grid Cassette
Integrated Fall break system bolted into hopper
Anti-Roll Back Flaps
Chevron Belt
Heavy Duty Plain Belt
High Spec Scraper Discharge Conveyor at Head Drum on Discharge Conveyor
Discharge Conveyor Underguard Length of Mid-Section
Pull Cord E-Stop
Canvas Dust Covers
Spray Bar at Head Drum on Discharge Conveyor
Full Length skirting rubber along Discharge Conveyor
Belt Weigher
Low Level Grease Lines to Head Drum
Overband Magnet on Discharge Conveyor with Hydraulic Kit and Support Frames
Radio Remote
T-Link Telematics (Aftermarket Option)

Ranger™ 6-24H HIGH LEVEL FEEDER

The Ranger™ 6-24H high level feeder, combines the highly versatile feeder system and stockpiling conveyor, allowing the operator to directly discharge from wheel loaders to reduce the amount of material handling on site. The fully mobile units can be used for a 'metered or controlled' feed of material into any ProStack products or other machines.

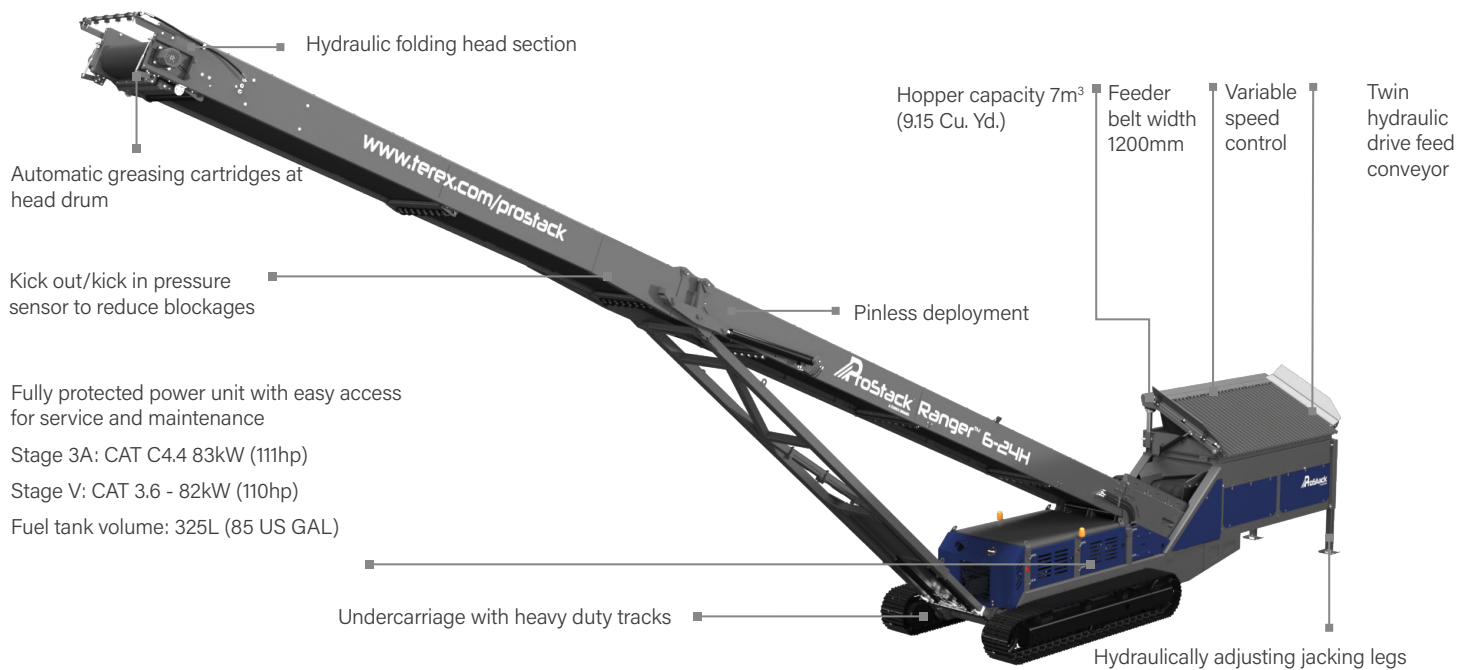

TRANSPORT DIMENSIONS	Ranger™ 6-24H
Length	19.5m (63' 11")
Width	2.75m (9')
Height	3.12m (10' 2")
Weight (Est.)	23,500kg (51,808lbs)

CONVEYOR DETAILS	Ranger™ 6-24H
Discharge conveyor length	22.5m (73' 10")
Feeder length	4.1m (13' 11")
Belt width	1200mm (48")
Discharge height	8m (26' 3") @ 18°
Max. discharge height	9.8m (32' 2") @ 24°
Production capacity	Up to 600 TPH (661 US TPH)

OPTIONS*
AR400 steel wear liners in hopper
4" or 6" tipping grid fitted to feed conveyor
12ft 2-Deck vibrating grid with radio control tipping bofor grid
Upgraded hopper with integrated fall break system
Twin hydraulic drive feed conveyor
Twin Hydraulic Drive Discharge Conveyor
Discharge conveyor drive drum upgraded to ceramic lagging
Discharge conveyor fitted with chevron belt
High spec SCS scraper discharge conveyor at head drum
Canvas dust covers complete with dust hood on discharge conveyor
Dust suppression water spray bar at head drum on discharge conveyor
Full length skirting rubber along discharge conveyor
Belt weigher option
Overband magnet on discharge conveyor with hydraulic kit and support frames
Hybrid
Radio remote to stop/start feed conveyor, raise/lower discharge conveyor and tip grid
Radio remote to track machine
Containerised freight

* Refer to order form for current listing of options available.

Ranger™ 6-24L

LOW LEVEL FEEDER

The Ranger™ 6-24L low level feeder allows the operator to directly discharge from wheel loaders and excavators at a significantly lower feed in height compared to standard hopper feeders. The unique design of the hopper allows for rear feeding which can be an advantage when operating in restricted areas.

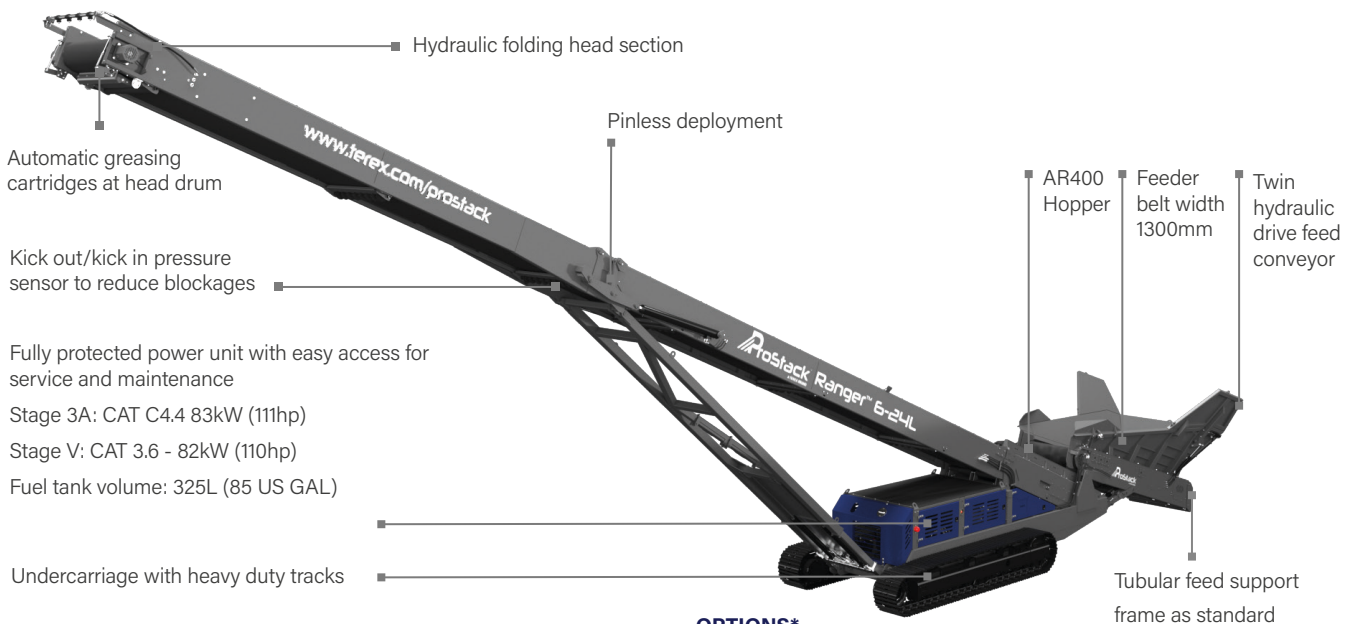

TRANSPORT DIMENSIONS	Ranger™ 6-24L
Length	19.74m (64' 9")
Width	2.75m (9')
Height	3.35m (11')
Weight (Est.)	24,700kg (54,454lbs)

CONVEYOR DETAILS	Ranger™ 6-24L
Discharge conveyor length	22.5m (73' 10")
Feeder length	4.1m (13' 11")
Belt width	1300mm (4' 3")
Discharge height	8m (26' 3") @ 18°
Max. discharge height	9.8m (32' 2") @ 24°
Production capacity	Up to 600 TPH (661 US TPH)

* Refer to order form for current listing of options available.

OPTIONS*

- AR400 steel liners bolted into hopper
- AR400 steel wear liners on hopper flares
- Large capacity hopper
- Feedboot lined with 6mm AR400 wearplate
- Feed conveyor drive drum upgraded to ceramic lagging
- Manually adjusting jacking legs
- Discharge conveyor drive drum upgraded to ceramic lagging
- Twin hydraulic drive discharge conveyor
- Discharge conveyor fitted with chevron belt
- High spec SCS scraper discharge conveyor at head drum
- Canvas dust covers complete with dust hood on discharge conveyor
- Spray bar at head drum on discharge conveyor
- Full length skirting rubber along discharge conveyor
- Belt weigher
- Overband magnet on discharge conveyor with hydraulic kit and support frames
- Hybrid
- Radio remote to stop/start feed conveyor and raise/lower discharge conveyor
- Radio remote to track machine
- Apron Feeder Max. Size: 240mm (9")
- Containerised freight

Ranger™ 6-24LS

ORBITAL FEEDER



Automatic greasing cartridges at head drum

The Ranger™ 6-24HS Orbital low level feeder features a rotating undercarriage which allows the conveyor to rotate a full 360° to provide increased versatility on site. With unrivalled portability and durability, the Ranger™ 6-24HS Orbital can operate in a wide variety of working environments. This conveyor can be integrated with crushers and screeners to stockpile material directly from the source. Site traffic will also be reduced, and it will remove the need for double handling of material. The machine can also be used as a mobile link conveyor.

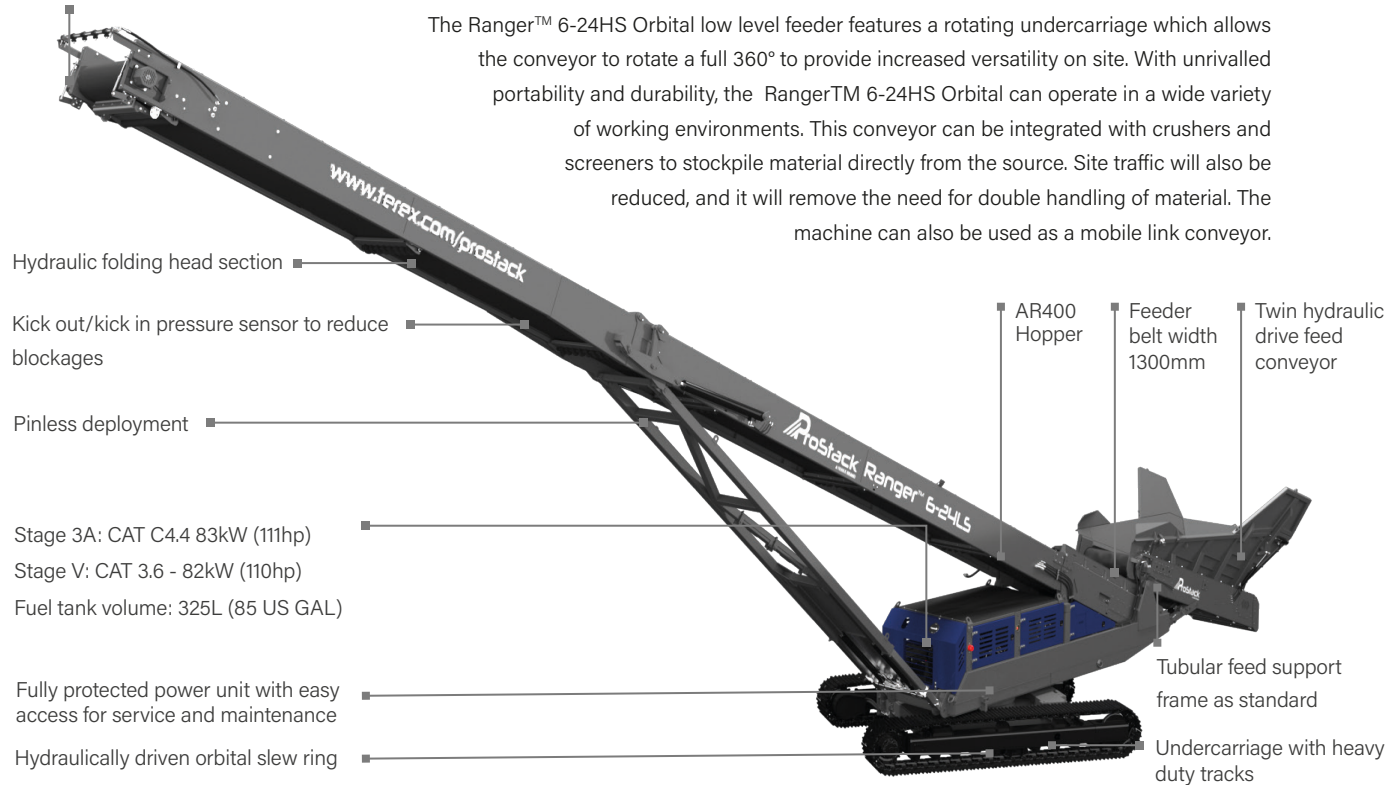

TRANSPORT DIMENSIONS	Ranger™ 6-24LS
Length	19.7m (64' 8")
Width	3.2m (10' 6")
Height	3.63m (11' 11")
Weight (Est.)	29,550kg (65,146lbs)

CONVEYOR DETAILS	Ranger™ 6-24LS
Discharge conveyor length	22.5m (73' 10")
Feeder length	4.1m (13' 11")
Belt width	1300mm (4' 3")
Discharge height	8m (26' 3") @ 18°
Max. discharge height	10.7m (35') @ 24°
Production capacity	Up to 600 TPH (661 US TPH)

OPTIONS*
AR400 steel liners bolted into hopper
Large capacity hopper
Feedboot lined with AR400 wearplate
Feed conveyor drive drum upgraded to ceramic lagging
Manually adjusting jacking legs
Discharge conveyor drive drum upgraded to ceramic lagging
Twin hydraulic drive discharge conveyor
Discharge conveyor fitted with chevron belt
High spec SCS scraper discharge conveyor at head drum
Canvas dust covers complete with dust hood on discharge conveyor
Spray bar at head drum on discharge conveyor
Full length skirting rubber along discharge conveyor
Belt weigher
Overband magnet on discharge conveyor with hydraulic kit and support frames
Apron Feeder Max. Size: 240mm (9")
Containerised freight

* Refer to order form for current listing of options available.

Ranger™ 6-24HS ORBITAL FEEDER



The Ranger™ 6-24HS Orbital high level feeder permits operators to directly discharge to the hopper/feeder from excavators or wheel loaders eliminating double handling of material on site. The rotating undercarriage allows the conveyor to rotate a full 360° which provides increased versatility on site. It can be used for a 'metered or controlled' feed of material when working as part of a crushing and screening train or in standalone applications.

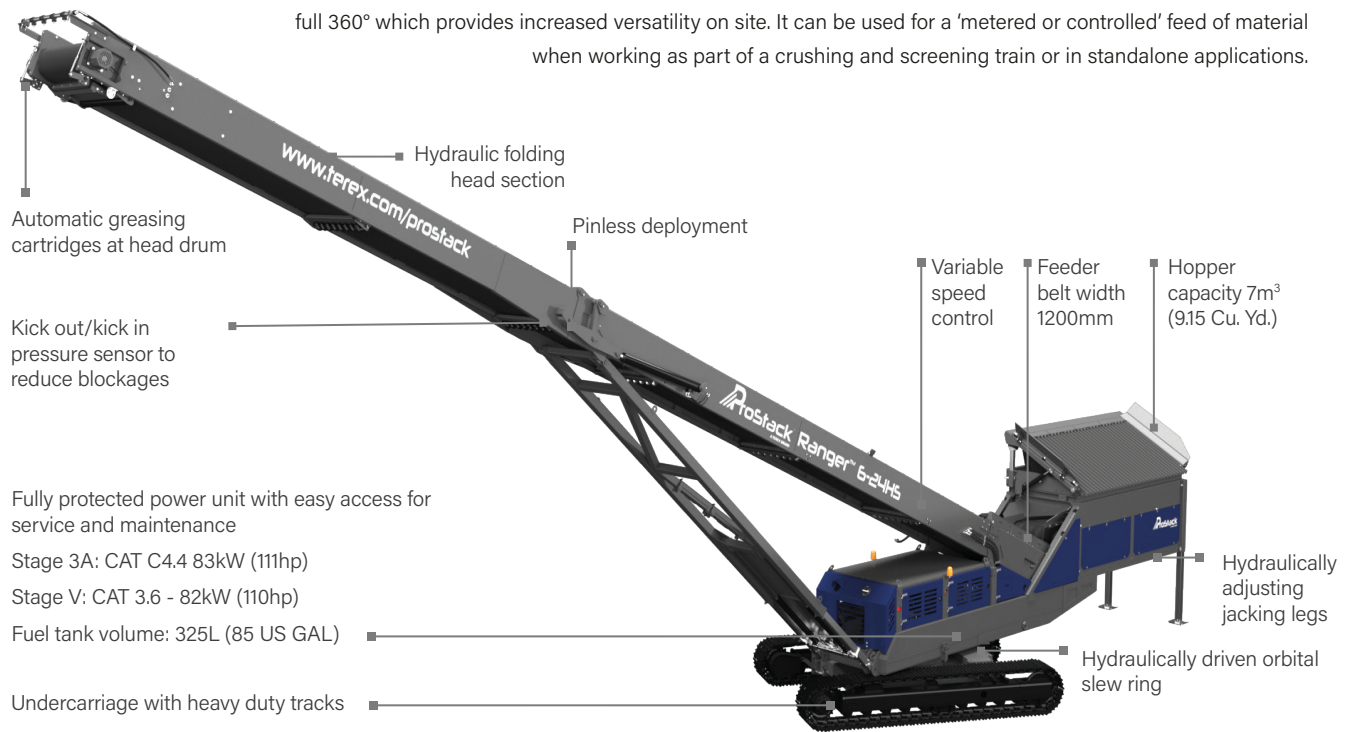

TRANSPORT DIMENSIONS Ranger™ 6-24HS

Length	19.5m (63')
Width	3.2m (10' 6")
Height	3.63m (11' 11")
Weight (Est.)	29,300kg (64,595lbs)

CONVEYOR DETAILS Ranger™ 6-24HS

Discharge conveyor length	22.5m (73' 10")
Feeder length	4.1m (13' 11")
Belt width	1200 mm (48")
Discharge height	8.80m (28' 2") @ 18°
Max. discharge height	10.7m (34' 6") @ 24°
Production capacity	Up to 600 TPH (661 US TPH)

OPTIONS*

- AR400 steel wear liners in hopper
- 4" or 6" tipping grid option
- 12ft 2-Deck vibrating grid with radio control tipping bofor grid
- Upgraded hopper with integrated Fall Break System
- Twin hydraulic drive feed conveyor
- Twin hydraulic drive discharge conveyor
- Discharge conveyor drive drum upgraded to ceramic lagging
- Discharge conveyor fitted with chevron belt
- High spec SCS scraper discharge conveyor at head drum
- Canvas dust covers complete with dust hood on discharge conveyor
- Spray bar at head drum on discharge conveyor
- Full length skirting rubber along discharge conveyor
- Belt weigher
- Overband magnet on discharge conveyor with hydraulic kit and support frames
- Containerised freight

* Refer to order form for current listing of options available.

Ranger™ 6-24HO ORGANIC FEEDER

The Ranger™ 6-24HO Organic feeder has been engineered specifically for the stockpiling and aerating of lower density, bulky materials such as soils, mulch, biomass and compost. The specifically designed organics hopper improves material flow eliminating bridging and ensures efficient movement of materials whilst the auger at the hopper outlet provides aeration and untangling solution therefore minimizing fluctuations in bulk density of organic materials.

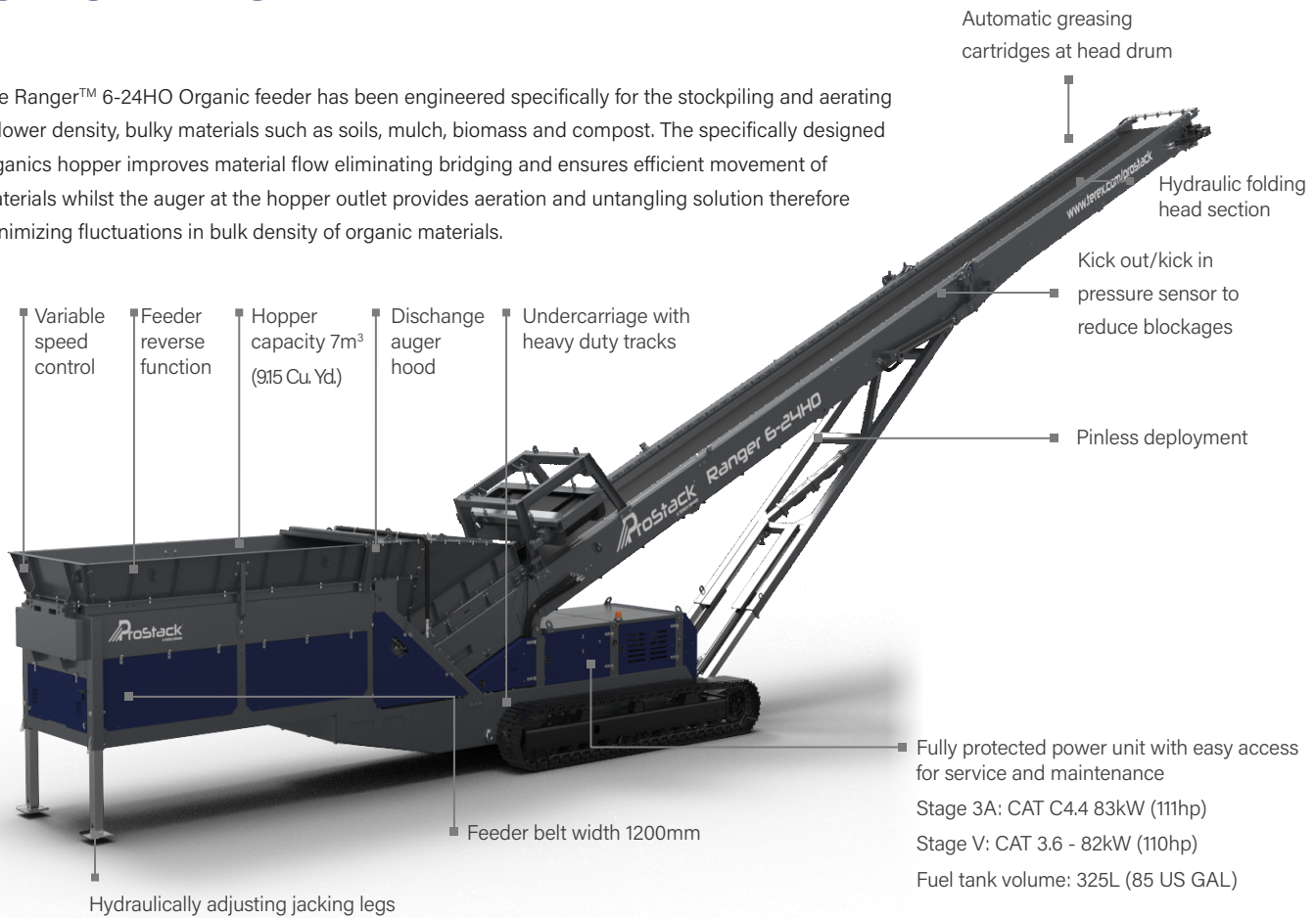

TRANSPORT DIMENSIONS	Ranger™ 6-24HO
Length	19.5m (63')
Width	2.7m (8' 8")
Height	3m (9' 8")
Weight (Est.)	24,350kg (53,682)

CONVEYOR DETAILS	Ranger™ 6-24HO
Discharge conveyor length	22.5m (73' 10")
Feeder length	4.1m (13' 11")
Belt width	1400 mm (56")
Discharge height	8.80m (28' 2") @ 18°
Max. discharge height	9.8m (32' 2") @ 24°

OPTIONS*
Discharge conveyor drive drum upgraded to ceramic lagging
Feed conveyor drive drum upgraded to ceramic lagging
High spec SCS scraper discharge conveyor at head drum
Discharge conveyor underguard length of mid-section
Canvas dust covers complete with dust hood on discharge conveyor
Spray bar at head drum on discharge conveyor
Belt eigher
Overband magnet on discharge conveyor with hydraulic kit and support frames
Hybrid
Radio remote to stop/start feed conveyor, raise/lower discharge conveyor
Radio Remote to track machine
Containerised freight

* Refer to order form for current listing of options available.



Ranger™ 6-24HSO ORBITAL ORGANIC FEEDER



Automatic greasing cartridges at head drum

The Ranger™ 6-24HSO Orbital Organic feeder features a rotating undercarriage providing increased versatility and is ideal for stockpiling and aerating of lower density, bulky materials such as soil, mulch, biomass and compost. Located at the hopper outlet, the auger provides aeration and an untangling solution for organic materials. The auger flips, rotates and regulates the flow of material minimising fluctuations in the bulk density of organic materials and is equipped with replaceable hardened paddle wear plates.



- Feeder reverse function
- Feeder belt width: 1200mm
- Hopper capacity 7m³ (915 Cu. Yd.)
- Discharge auger hood

- Variable speed control
- Hydraulically adjusting jacking legs

www.terex.com/prostack

- Hydraulic folding head section
- Kick out/kick in pressure sensor to reduce blockages

- Pinless deployment
- Fully protected power unit with easy access for service and maintenance
 - Stage 3A: CAT C4.4 83kW (111hp)
 - Stage V: CAT C3.6 - 82kW (110hp)
 - Fuel tank volume: 325L (85 US GAL)

- Hydraulically driven orbital slew ring

TRANSPORT DIMENSIONS	Ranger™ 6-24HSO ORBITAL ORGANIC
Length	22.5m (73' 10")
Width	3.2m (10' 6")
Height	3.63m (11' 11")
Weight (Est.)	29,300kg (64,595lbs)

CONVEYOR DETAILS	Ranger™ 6-24HSO ORBITAL ORGANIC
Discharge conveyor length	22.5m (73' 10")
Feeder length	4.1m (13' 11")
Belt width	1400 mm (56")
Discharge height	8m (26' 3") @ 18°
Max. discharge height	10.7m (34' 6") @ 24°
Production capacity	Up to 600+TPH (661 US TPH)

OPTIONS*
Discharge conveyor drive drum upgraded to ceramic lagging
Feed conveyor drive drum upgraded to ceramic lagging
High spec SCS scraper discharge conveyor at head drum
Discharge conveyor underguard length of mid-section
Canvas dust covers complete with dust hood on discharge conveyor
Spray bar at head drum on discharge conveyor
Belt weigher
Overband magnet on discharge conveyor with hydraulic kit and support frames
Containerised freight

* Refer to order form for current listing of options available.

** Contact factory for availability.



Ranger™ 6-27H HIGH LEVEL FEEDER

The Ranger™ 6-27H high level feeder features the longest standard conveyor length within the Ranger series while maintaining a high level of robustness. It combines the highly versatile feeder system and stockpiling conveyor, to the operator to directly discharge from wheel loaders to reduce the amount of material handling on site. The fully mobile units can be used for a 'metered or controlled' feed of material into any ProStack products or other machines.

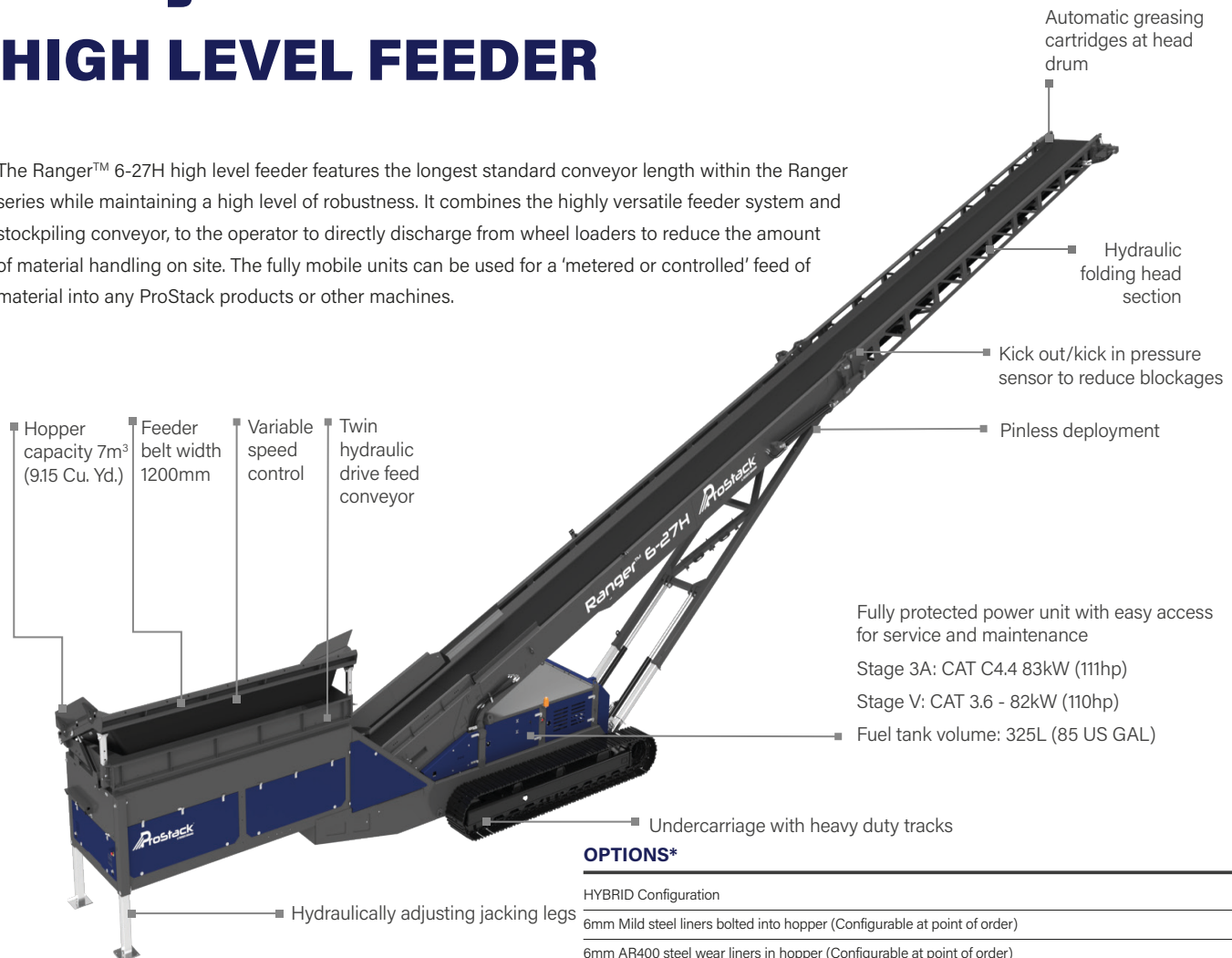

TRANSPORT DIMENSIONS	Ranger™ 6-27H
Length	19.5m (63')
Width	2.7m (8' 8")
Height	3.2m (10')
Weight (Est.)	25,622kg (56,487lbs)

CONVEYOR DETAILS	Ranger™ 6-27H
Discharge conveyor length	25.9m (85')
Feeder length	4.1m (13' 11")
Belt width	1200 mm (48")
Discharge height	9m (29' 8") @ 18°
Max. discharge height	11.62m (38' 2") @ 24°
Production capacity	Up to 600 TPH

* Refer to order form for current listing of options available.

OPTIONS*

HYBRID Configuration
6mm Mild steel liners bolted into hopper (Configurable at point of order)
6mm AR400 steel wear liners in hopper (Configurable at point of order)
Feedboot Lined with 6mm AR400 Wearplate (Configurable at Point of Order)
Integrated Fall break system bolted into hopper
12ft 2-Deck vibrating grid c/w radio control tipping bofor grid 100mm (4") top deck and 38 mm (1 1/2") bottom deck mesh
Hopper upgraded to 500mm (20") extension 9m3 (12yds3) C/W Integrated Fall Break System bolted into Hopper.
Hopper upgraded to 700mm (28") extension 12m3 (15yds3) C/W Integrated Fall Break System bolted into Hopper.
Machine prepared hydraulically to tip a standard grid. Includes Remote Control. NO GRID
Machine prepared hydraulically for DDVG option. Includes Remote Control. NO Vibrating Grid
Double Deck Vibrating Grid 4" /100mm Spacing on top deck: (please advise bottom deck mesh Aperture)
Twin Hydraulic Drive Feed Conveyor
Discharge Conveyor Drive Drum upgraded to Ceramic Lagging
Feed Conveyor Drive Drum Upgraded to Ceramic Lagging
Conveyor Fitted With Chevron Belt EP315/3 Ply x 3+1.5 Covers
Conveyor Fitted With Heavy Duty Plain Belt EP500 4 Ply x 8+2 Covers
High Spec Scraper Discharge Conveyor at Head Drum (only with Plain Belt)
Discharge Conveyor Underguard Length of Mid-Section
Pull Cord E-Stop Running Length Of Conveyor
Full Length skirting rubber along Discharge Conveyor
Belt Weigher
Grease Lines to Head Drum
Overband Magnet on Discharge Conveyor with Hydraulic Kit and Support Frames
Radio Remote to Stop / Start Feed Conveyor, Raise / Lower Discharge Conveyor and Tip Grid
ISO 68 Hydraulic Oil - (Recommended For Ambient Temperatures Between 15 - 50°)
Telemetry System c/w 3 years data subscription (Belt Weigher Option recommended)(Unavailable for Tier 3)
Special paint colour (if different from above). RAL must be specified on order

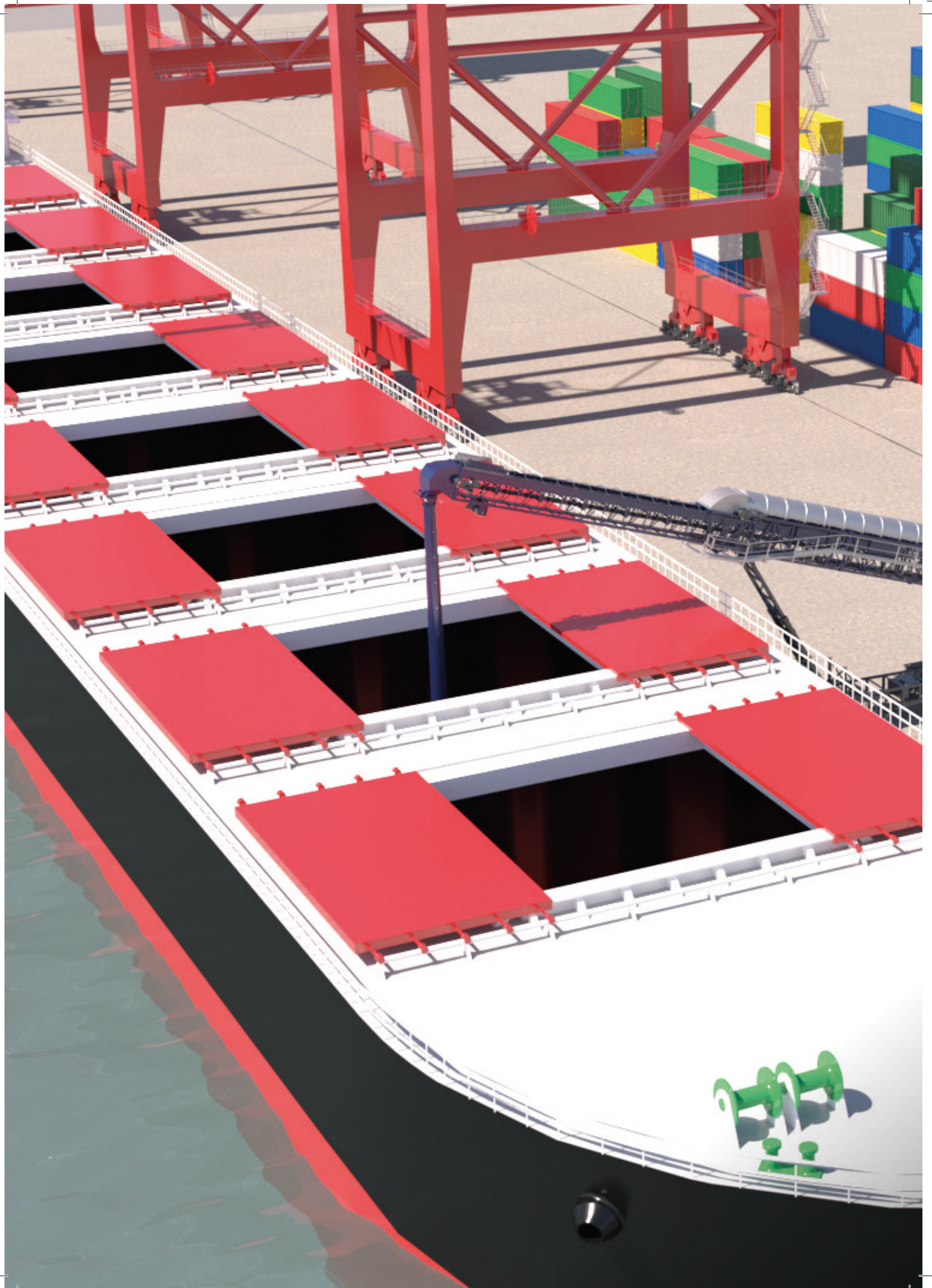



Tailor Made Solutions from ProStack

Creating bespoke and tailored machines for your Ports operation is at the heart of ProStack. We understand there are a multitude of variations from vessel beam, quayside space to vessel freeboard and proudly offer a complete range of conveyor lengths to cover all loading scenarios. This variability in length allows the range to load from small barges in inland river terminals to deep ocean going vessels such as baby capesize.

Each Telson, Manta and Hornet bulk handling solution can be customised to suit the demands of individual ports or terminal, with careful focus being placed on the individual application of material(s) being conveyed.

While there are several existing models, bespoke and tailored machines are at the heart of the Manta range. We will work hard to create the best solutions for customers handling dry bulk cargo from ocean going vessels, ensuring their equipment works at optimum levels for their specific operation. By tailoring the machines to a customer's product, terminal and specifications, our equipment will ensure optimal results, return on investment and ultimately increased profits.



FOR FURTHER INFORMATION PLEASE CONTACT:

Tel: +44 (0) 288 771 8500

Email: ProStack@terex.com

www.terex.com/prostack



ProStack[™]
A TEREX BRAND

AFTER SALES SUPPORT

We provide comprehensive after sales support, maintenance support, provision of spare parts, and on-call customer help & advice.

- ✓ Parts
- ✓ Warranty
- ✓ Service
- ✓ 24/7 Help Desk
- ✓ Telematics
- ✓ Training

Effective Nov 2022. Product specifications and prices are subject to change without notice or obligation. The photographs and/or drawings in this document are for illustrative purposes only. Refer to the appropriate Operator's Manual for instructions on the proper use of this equipment. Failure to follow the appropriate Operator's Manual when using our equipment or to otherwise act irresponsibly may result in serious injury or death. The only warranty applicable to our equipment is the standard written warranty applicable to the particular product and sale and Terex USA LTD. makes no other warranty, express or implied. Products and services listed may be trademarks, service marks or trade-names of Terex Corporation and/or its subsidiaries in the USA and other countries. All rights are reserved. Terex® and ProStack is a registered trademark of Terex Corporation in the USA and many other countries.

Copyright May 2024 Terex USA Ltd.